

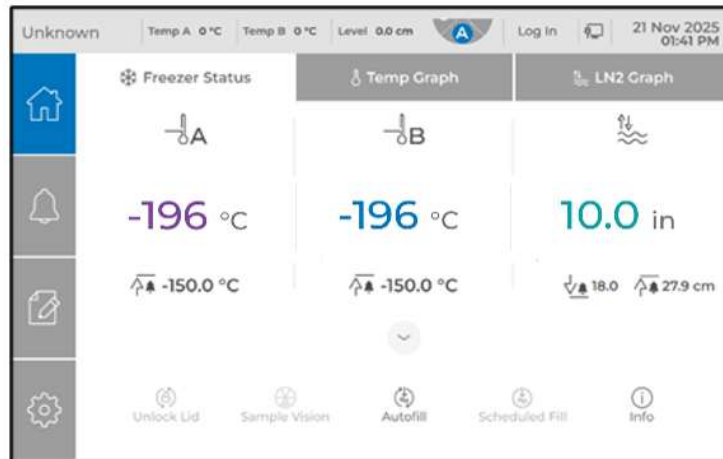

MVE HE Freezers With CryoVerse™ Connect

Technical Manual



MVE Biological Solutions

3055 Torrington Drive
Ball Ground, GA 30107 USA

+1-844-683-2796

www.mvebio.com



**Intended Use & Indication for Use
for Cryogenic Storage and/or Transport****LIFE SCIENCE INTENDED USE STATEMENT STORAGE ONLY**

MVE FREEZERS ARE INTENDED FOR THE INDICATION OF PRESERVING HUMAN BIOLOGICAL PRODUCTS, SAMPLES, AND/OR SPECIMENS (E.G., BLOOD, BLOOD PRODUCTS, CELLS, TISSUES, ETC.) AT CRYOGENIC AND ULTRACOLD TEMPERATURES DURING STORAGE.

STORAGE AND TRANSPORT

MVE DEWARS AND VAPOR SHIPPERS ARE INTENDED FOR THE INDICATION OF PRESERVING HUMAN BIOLOGICAL PRODUCTS, SAMPLES, OR SPECIMENS (E.G., BLOOD, BLOOD PRODUCTS, SAMPLES, OR SPECIMENTS (E.G., BLOOD PRODUCTS, CELLS, TISSUES, ETC.) AT CRYOGENIC AND ULTRACOLD TEMPERATURES DURING STORAGE AND/OR TRANSPORTATION.

Customer / Technical Service:

Location	Phone	Fax	Email
The Americas	844-MVE-CRYO +1 844-683-2796	+1 470 552 2200	customerservice.usa@mvebio.com techservice@mvebio.com
Asia, Australia, Pacific Rim	Asia: +1 844-683- 2796 Australia: +61 (2) 974 94333	+61 (2) 974 94666	csasia@mvebio.com techservice@mvebio.com
Europe	+44 (0) 7718 488236	Not Available	customerservice.europe@mvebio.com techservice@mvebio.com

Read this manual. Failure to follow the instructions in this manual can result in damage to the unit, injury to personnel, and/or poor equipment performance. This manual covers the use and maintenance of MVE Cryogenic Freezers and the CryoVerse™ Connect Control system. It is intended for use by qualified personnel only. Installation, service, and maintenance should only be performed by an authorized MVE Distributor. If any alarms occur, contact your authorized MVE Distributor or Technical Service.

NOTE: All models are Class II 510K exempt, externally powered, continuous operation medical devices. They are not suitable for use with flammable anesthetics. This equipment has been tested and found to comply with the limits for medical devices to IEC 61010-1:2010+A1:2016 and EMC standard IEC 60601-1-2:2020.



Failure to follow MVE's best operating practices, as set forth in the operating manual, can result in loss of contents.	Active monitoring required.	Investigate all alarms or abnormal operating conditions immediately and address root causes.	Contact your Distributor for support.
Si no se siguen las prácticas operativas recomendadas de MVE, como se establece en el manual de operaciones, podría resultar en la pérdida de contenidos.	Se requiere un control activo.	Investigue todas las alarmas o condiciones operativas anormales de inmediato y aborde las causas de origen.	Comuníquese con su distribuidor para obtener ayuda.
Il mancato rispetto delle migliori procedure operative di MVE, come descritto nel Manuale di funzionamento, può comportare la perdita di contenuto.	Richiede monitoraggio attivo.	Esaminare immediatamente tutti gli allarmi e condizioni operative anomale e affrontare le cause radice.	Contattare il distributore per supporto.
Ne pas suivre les pratiques exemplaires d'exploitation de MVE, conformément au manuel d'utilisation, peut entraîner la perte de contenu.	Surveillance active nécessaire.	Enquêtez immédiatement sur toutes les alarmes ou les conditions d'exploitation anormales, et attaquiez-vous aux causes profondes.	Contactez votre distributeur pour obtenir de l'assistance.
Die Nichtbeachtung der in dieser Betriebsanleitung aufgeführten bewährten Praktiken von MVE kann Inhaltsverluste nach sich ziehen.	Aktive Überwachung erforderlich.	Überprüfen Sie alle Alarme und ungewöhnlichen Betriebsbedingungen unverzüglich und beheben Sie die Ursache.	Wenden Sie sich bei Bedarf an Ihren Händler.

MVE Biological Solutions US, LLC reserves the right to discontinue its products, or change the prices, materials, equipment, quality, descriptions, specifications and/or processes to its products at any time without prior notice and with no further obligation or consequence. All rights not expressly stated herein are reserved by us, as applicable. Copyright © 2026 MVE Biological Solutions US, LLC.



Table of Contents

- 1 Symbols, Safety, First Aid, Warnings & Cautions.....1
 - 1.1 Symbols Used1
 - 1.2 Liquid Nitrogen Safety2
 - 1.3 Recommended First Aid3
 - 1.4 Pinch Hazard.....3
- 2 Certifications and Listings..... 4
- 3 Home Screen5
 - 3.1 Home Screen Information.....5
 - 3.2 Home Screen Temperature & LN2 Level Hot Keys.....5
 - 3.3 Home Screen LN2 Autofill & Scheduled Fill Hot Keys.....6
 - 3.4 Freezer Info Hot Key6
 - 3.5 Temp A & B LN2 level Graphs7
- 4 Logging in and Setting up Usernames and Passwords.....9
 - 4.1 Log in & Setting up Usernames & Passwords9
 - 4.2 About Usernames & Passwords.....9
- 5 Alarms Screen..... 13
 - 5.1 Silence Alarm (Mute) Slide to Silence Alarm..... 13
 - 5.2 Alarms Screen 13
 - 5.3 Alarm Descriptions Critical & Non-Critical..... 15
 - 5.4 Alarm Beacon Light Descriptions Critical & Non-Critical..... 16
- 6 Journal, Event, & Data Tabs 17
 - 6.1 Journal Tab..... 17
 - 6.2 Event Tab..... 18
 - 6.3 Data Tab..... 20
- 7 Settings Menu (Overview) 21
- 8 Temperature, Inlet/Bypass & Stuck Valve Alarm Settings..... 22
 - 8.1 Temperature A & B Alarm Settings..... 22
 - 8.2 Temperature Inlet/Bypass & Stuck Valve Alarm Settings..... 23
 - 8.3 Temperature A & B, Inlet/Bypass Sensor Calibration 23
 - 8.4 Temperature A & B, High Alarm Test..... 23
 - 8.5 Temperature Unit of Measure (UOM) Settings 23
 - 8.6 Liquid Nitrogen Saturation Temperature Adjustment..... 23
- 9 Liquid Nitrogen Level & Alarm Setpoints..... 25



- 9.1 Adjusting Level and Alarm Setpoints..... 25
- 10 Liquid Nitrogen Advanced Fill Settings Menu 26
 - 10.1 Allow Manual Fill (Without Logging in) 26
 - 10.2 Auto Fill Control 26
 - 10.3 Max Fill Time..... 26
 - 10.4 Scheduled Fill 27
 - 10.5 Liquid Level Calibration..... 27
 - 10.6 Restricted Idle 28
- 11 Liquid Nitrogen Level Dipstick Procedure..... 29
 - 11.1 Dipstick Procedure 29
 - 11.2 Overfill Protection 30
 - 11.3 Restricted Idle Protection 30
 - 11.4 Liquid Nitrogen Usage..... 30
 - 11.5 OFAF (One Fill All Fill) Settings..... 30
 - 11.6 OFAF Cables & Setup 32
- 12 General Settings Menu..... 33
 - 12.1 Press Settings to Access General Settings..... 33
 - 12.2 Freezer Name 34
 - 12.3 Time, Date, Language, & Log Interval Settings 34
 - 12.4 Logging Interval..... 35
 - 12.5 Freezer & Controller Serial Numbers 35
- 13 Advanced Settings Menu 36
 - 13.1 Press Settings to Access Advanced Settings..... 36
 - 13.2 Firmware, Restore Default, Factory Reset, & Restart Controller..... 36
 - 13.3 Restore To Defaults..... 37
 - 13.4 Factory Reset 38
 - 13.5 CryoVerse Connect Controller Default Settings..... 38
 - 13.6 Restart Controller 40
 - 13.7 Clone Config Settings..... 40
- 14 Display & Output Settings..... 41
 - 14.1 Press Settings to Access Display & Output..... 41
- 15 Network Settings 44
 - 15.1 Press Settings to Access Network Settings..... 44
 - 15.2 Wi-Fi & Ethernet Settings 44
 - 15.3 Email Config Settings..... 46



- 16 Accessories Settings 48
 - 16.1 Press Settings to access Accessories..... 48
- 17 Licenses..... 48
 - 17.1 Touch Settings to Access Licenses Screen 48
- 18 MVE HE Freezer Product Information.....49
 - 18.1 MVE HE Freezer Components49
 - 18.2 MVE HE Series Model Description.....49
 - 18.3 MVE HE Freezer Specifications50
- 19 MVE CryoVerse™ Connect Controller Product Information 52
 - 19.1 MVE CryoVerse™ Display System Descriptions..... 52
 - 19.2 CryoVerse Connect Electrical and Level Connections..... 53
 - 19.3 CryoVerse Connect 25-Pin Female Freezer Wiring Harness Connections..... 53
- 20 MVE CryoVerse™ Connect Controller Specifications..... 55
- 21 MVE Plumbing System 56
 - 21.1 MVE HE Plumbing Components 56
- 22 Operating Environment 57
 - 22.1 Ambient Temperature and Relative Humidity 57
- 23 Infrastructure Requirements 58
- 24 Installation (Uncrating) 59
 - 24.1 Items Included with MVE Freezers..... 59
 - 24.2 Uncrate Freezer..... 59
- 25 Installation and Freezer Setup 61
 - 25.1 Setting up MVE Freezer 61
- 26 CryoVerse™ Connect Initial Pre-Setup (Quick Start & Initial Fill) 64
 - 26.1 CryoVerse™ Connect Controller Pre-Setup Screen (Quick Start) 64
 - 26.2 Start Initial Fill Cycle 68
 - 26.3 Alarm Conditions During the Initial Fill Cycle..... 69
- 27 MVE Freezer Theory of Operations.....70
 - 27.1 Temperature Measurement (Theory).....70
 - 27.2 Automatic Liquid Nitrogen Level Measurement (Theory) 71
 - 27.3 LN2 Volume Per Inch (Theory)..... 73
 - 27.4 MVE CryoVerse™ Connect Functions and Features74
- 28 Preventive Maintenance 75
 - 28.1 Periodic Preventive Maintenance Schedule..... 75
 - 28.2 Freezer Maintenance..... 75



29 Preventive Maintenance Procedures..... 77

 29.1 Level Verification 77

 29.2 Verify Adequate LN2 Supply & Pressure..... 77

 29.3 Plumbing Leak Check..... 77

 29.4 Level Alarm Test.....78

 29.5 Thaw Freezer Lid79

 29.6 Lid Switch & Hinge Inspection.....79

 29.7 Folding Step Inspection.....79

30 Service & Parts Replacements..... 80

 30.1 Inline Filter Replacement 80

 30.2 Solenoid Valve Replacement..... 80

 30.3 Purge Valve Replacement.....81

 30.4 Relief Valve Replacement.....82

 30.5 Lid Gasket Service & Replacement82

 30.6 Battery Backup Replacement83

31 Replacement Parts and Accessories.....86

32 Troubleshooting Quick Reference87

33 EN Compliance Table.....89

34 Appendix (Reference Tables).....94

35 Decontamination and Sanitizing.....95



List of Figures

Figure 1. Home Screen	5
Figure 2. Temp A & B Level (Hot Keys)	5
Figure 3. Home Hot Keys.....	6
Figure 4. Freezer Information Page	6
Figure 5. Temp & LN2 Graph Access Keys	7
Figure 6. Temp A & B Graph & Range Settings	7
Figure 7. Temp Graph Range Selected	8
Figure 8. Temp A&B Graph Display	8
Figure 9. LN2 Graph Display.....	8
Figure 10. Log In Icon.....	9
Figure 11. Log In Screens	10
Figure 12. Intuitive Keypad	10
Figure 13. Log In Button.....	10
Figure 14. Add User Screen	11
Figure 15. Select Admin, Distributor, or User	11
Figure 16. Select User	11
Figure 17. Delete User.....	12
Figure 18. Forgot Password Information.....	12
Figure 19. Alarm Slide to Silence Bar.....	13
Figure 20. Alarm Status Screen.....	13
Figure 21. Alarm Slide to Silence Bar.....	14
Figure 22. Journal Tab	17
Figure 23. Intuitive Keypad	17
Figure 24. Journal Cancel, Save & Edit Log.....	18
Figure 25. Event Tab.....	18
Figure 26. Event Range Setting	19
Figure 27. Event Download Tab.....	19
Figure 28. Data Tab.....	20
Figure 29. Data Range Tab.....	20
Figure 30. Settings Screen	21
Figure 31. Temperature Settings	22
Figure 32. Liquid Level Settings.....	25
Figure 33. Liquid Level Setpoints	25
Figure 34. Advanced Fill Settings	26
Figure 35. Scheduled Fill Time Settings.....	27
Figure 36. Advanced LN2 Screen	27
Figure 37. MVE Dipstick Channel Location.....	29
Figure 38. Com 1 Settings.....	31
Figure 39. Baud Rate Selection	31
Figure 40. OFAF Settings.....	32
Figure 41. Typical OFAF network setup with four controllers.....	32
Figure 42. General Settings Screen	33
Figure 43. Freezer Name Location.....	34
Figure 44. Date & Time Screen.....	34
Figure 45. Logging Interval Settings	35
Figure 46. Product Serial Numbers.....	35



Figure 47. Advanced Settings..... 36

Figure 48. Update Firmware Selection..... 36

Figure 49. Done Searching for Firmware 37

Figure 50. Restore To Defaults..... 37

Figure 51. Factory Reset..... 38

Figure 52. Restart Controller Location 40

Figure 53. Clone Config Settings..... 40

Figure 54. USB Device Transfer or Cancel Location..... 41

Figure 55. Unit of Measure Settings 41

Figure 56. UOM Temp Settings 42

Figure 57. UOM LN2 Level Settings 42

Figure 58. Date Format Settings Location..... 42

Figure 59. Hour Format Settings Location..... 43

Figure 60. Screen Brightness 43

Figure 61. Network Settings..... 44

Figure 62. Com Port Location..... 44

Figure 63. WIFI Location 45

Figure 64. WIFI Network Name 45

Figure 65. Network Name Detected 45

Figure 66. Email Settings Location 46

Figure 67. Email Notifications 46

Figure 68. Email Journals, Event, and Data..... 47

Figure 69. Accessories Location..... 48

Figure 70. License Location..... 48

Figure 71. MVE HE Freezers & top view showing offset neck and P and R turn-trays.50

Figure 72. MVE CryoVerse™ Connect Controller & Keypad 52

Figure 73. CryoVerse Connect Electrical & Level I/O 53

Figure 74. MVE HE Plumbing Overview..... 56

Figure 75. Crated & Uncrated Freezer..... 59

Figure 76. Example Forklift Removal of Freezer from Pallet..... 60

Figure 77. Removal of Pallet from Underneath Freezer..... 60

Figure 78. Temperature 3-Sensor Tube 61

Figure 79. Temperature Sensor, Liquid Level, Freezer Harness and DC Power Connections 62

Figure 81: DC Power Supply Connection 64

Figure 82: MVE Startup Window..... 64

Figure 83. Initial Setup Screen..... 65

Figure 84: Slide to Silence Alarm 65

Figure 85: Log in Icon 66

Figure 86. Home Screen Settings Location..... 66

Figure 87. Home Screen Hot Keys Location..... 67

Figure 88. Temperature Sensor Platinum’s Linear Relationship..... 70

Figure 89. Example of automatic level control parameters..... 72

Figure 90. Illustration showing LN2 as the refrigerant..... 73



List of Tables

Table 1. Important Safety Symbols	1
Table 2. Alarm Descriptions	16
Table 3. LN2 Saturation Temp vs. Altitude.....	24
Table 4. CryoVerse™ Connect Default Settings	38
Table 5. MVE Nomenclature Definitions.....	49
Table 6. MVE HE 800 Series Freezer Specifications.....	50
Table 7. MVE HE 1500 Series Freezer Specifications.....	51
Table 8. MVE HE 1800 Series Freezer Specifications.....	51
Table 9. Controller Keypad	52
Table 10. CryoVerse Connect Connections.....	53
Table 11. 25-Pin Connections.....	54
Table 12. Specifications.....	55
Table 13. MVE HE Plumbing Component Part Numbers.....	56
Table 14. Infrastructure Requirements	58
Table 15. LN2 Volume Per Inch (Theory).....	73
Table 16. Periodic Preventive Maintenance Schedule	75
Table 17. Guidance and manufacturer’s declaration – electromagnetic emissions for all CryoVerse Controller (See 5.2.2.1 C).	89
Table 18. Guidance and manufacturer’s declaration – electromagnetic immunity – for all CryoVerse™ Connect Controller (See 5.2.2.1 F)	89
Table 19. Guidance and manufacturer’s declaration – electromagnetic immunity – for all CryoVerse Controller (See 5.2.2.2)	90
Table 20. Recommended separation distances between portable and mobile RF communications equipment and the CryoVerse™ Connect Controller systems that are not life supporting (See 5.2.2.2)	92
Table 21. Temperature vs. Resistance Output (ohms) for Pt-1000 Temperature Sensors	94



















1 Symbols, Safety, First Aid, Warnings & Cautions

1.1 Symbols Used

Table 1 shows the symbols that are used in this manual, on the device, and on device packaging.

Table 1. Important Safety Symbols

Symbol	Title	Description
	Operating Instructions	Read the operating instructions for additional information when operating this device.
	Serial Number	Unique identifier for the device.
	Model Number	MVE model number for the device.
	Caution	Indicates a potentially hazardous situation when operating the device that may result in minor to moderate injury or property damage.
	Warning	Indicates a potentially hazardous situation when operating the device that could result in serious injury or property damage.
	Warning; Low Temperature	Indicates low temperature or freezing conditions. Avoid exposure to skin, eyes, and clothing.
	Warning; Asphyxiating Atmosphere	Indicates the potential for an oxygen-depleted atmosphere due to nitrogen vapor. Operate device in a well-ventilated area.
	Warning; Electricity	Indicates a potential electrical hazard. Avoid contact with electricity.
	Warning; Explosive	Indicates a potential explosive hazard; the expansion ratio of liquid nitrogen to gas is 1:700 and can cause explosive conditions if placed into a sealed container.
	Wear Protective Gloves	Wear thermal gloves during the indicated procedures.
	Wear a Face Shield	Wear a face shield during the indicated procedures.
	Do Not Push	Indicates the area of the freezer that should not be pushed due to the potential for tipping.
	Temperature Limit	Indicates the minimum and maximum temperatures at which the freezer should be stored or transported.
	Humidity Limit	Indicates the minimum and maximum humidity at which the freezer should be stored or transported.
	SGS Listed Mark for US and Canada	MVE Cryogenic Freezers conform to relevant SGS safety standards.
	CE Mark	MVE Cryogenic Freezers are assessed to meet electrical safety requirements for Europe.
	Manufacturer	Indicates the manufacturer's name and address.



1.2 Liquid Nitrogen Safety

This section reviews the safety guidelines for MVE High Efficiency (HE) Series freezers. Read before using this equipment. This product is intended for use by MVE Trained personnel only. All service and maintenance should be performed by MVE Trained personnel.

Liquid Nitrogen Safety

Liquid nitrogen (LN2) is used in MVE Cryogenic Freezers as a refrigerant. Understanding potential hazards and following safety precautions is important when handling LN2 and these freezers. Nitrogen is a colorless, odorless, and tasteless gas that makes up approximately 78.1% of the Earth's atmosphere in its gaseous state. LN2 becomes vapor at temperatures greater than -320.8°F (-196°C). In liquid state, nitrogen has a temperature range from -320.4°F to -346°F (-195.8°C to -210°C).



- Nitrogen vapor is a potential asphyxiant as it displaces Oxygen (O₂) in confined spaces. Rapid suffocation can occur without warning in an Oxygen-deficient atmosphere (less than 19.5% O₂). MVE Cryogenic Freezers must be installed and operated in well-ventilated areas.



- DO NOT vent container in confined spaces.
- DO NOT enter confined spaces where excess nitrogen gas may be present.
- If exposure has occurred move to ventilated area or fresh air. If breathing is difficult, supplement oxygen may be required. If not breathing, give artificial respiration, and SEEK IMMEDIATE MEDICAL ATTENTION!



- Contact with liquid nitrogen or uninsulated equipment containing nitrogen can result in cold contact burns or tissue damage. Nitrogen vapor can cause damage to skin or eyes.



- In the case of frostbite, warm areas with warm water not exceeding 105°F (40°C) and SEEK IMMEDIATE MEDICAL ATTENTION!



- Never place LN₂ in a sealed container without a pressure relief device. The expansion ratio of liquid nitrogen to gaseous nitrogen is 1 to 700 (1 cubic foot of liquid nitrogen becomes 700 cubic feet of gaseous nitrogen when evaporated).



Recommended protective clothing



- Cryogenic gloves (loose fitting)
- Full-face shield or chemical splash goggles



- Cryogenic apron
- Long sleeve shirt and cuffless pants
- Closed toe shoes (no sandals)

General lab air exchange rate minimums are typically sufficient for LN₂ freezers; however, recommend consulting with your Health and Human Safety Officer or equivalent group. Oxygen monitoring systems are strongly recommended for any LN₂ setups.



Equipment Usage

Cryogenic freezers must be operated in accordance with the manufacturer/supplier instructions. Cryo Freezers are non-pressurized vessels and are vented through the lid into the surrounding environment. Safety instructions are posted on the side of each freezer. Cryogenic freezers must be kept in a well-ventilated area protected from weather and away from heat sources. In applications that use a modular liquid cylinder as a source of LN₂, the supply will need to be replenished at regular intervals to ensure proper operation of the freezer. When exchanging liquid cylinders, follow the below procedure:

2. Allow all plumbing components to warm to room temperature before attempting to change supplies.
3. Close all valves associated with the liquid supply cylinder.
4. Relieve pressure in the plumbing by initiating a brief fill by pressing “Start Fill”.
5. Loosen the plumbing connection for the transfer hose at the liquid cylinder.
6. Remove empty liquid cylinder and replace with full liquid cylinder pressurized to 22 - 35 psig (1.52 - 2.41 bar).
7. Attach the transfer hose to the plumbing connection on the liquid cylinder. Ensure that the hose is connected to the connection labeled “LIQUID”.
8. Tighten the transfer hose plumbing connection at the liquid cylinder.
9. Open the liquid supply valve on the liquid cylinder.
10. Inspect plumbing for audible and visual leaks. Repair if necessary.
11. Manually initiate a fill to verify proper operation.

1.3 Recommended First Aid

Every site that stores and uses LN₂ should have an appropriate Material Safety Data Sheet (MSDS) present. The MSDS may be obtained from the manufacturer/distributor. The MSDS will specify the symptoms of overexposure and first aid to be used. Here is a typical summary.

- If symptoms of asphyxia such as headache, drowsiness, dizziness, excitation, excess salivation, vomiting, or unconsciousness are observed, remove to fresh air. If breathing has stopped, give artificial respiration. **CALL A PHYSICIAN IMMEDIATELY.** If breathing is difficult, supplemental oxygen may be required.
- If exposure to cryogenic liquids or cold vapor occurs, restore tissue to normal, body temperature (37°C) as rapidly as possible, and then protect the injured tissue from further damage and infection. Rapid warming of the affected areas is best achieved by bathing it in warm water. The temperature of the water used should not exceed 105°F (40°C). Under no circumstances should the frozen part be rubbed either before or after warming. If the eyes are involved, flush them thoroughly with warm water for at least 15 minutes. In case of massive exposure, remove clothing while showering with warm water. The patient should not drink alcohol or smoke. **CALL A PHYSICIAN IMMEDIATELY.**

1.4 Pinch Hazard



CAUTION: Pinch hazard, use caution when opening and closing the freezer lid, folding steps, plumbing shroud and electrical enclosures. Potential pinch hazards exist on the hinged step, freezer lid, and rotating turn tray if not operated properly. Carefully raise and lower the step and freezer lid with caution. Rotate and stop the turn tray slowly and with caution.



2 Certifications and Listings

All fully automatic MVE cryogenic HE freezer systems are equipped with the CryoVerse Connect controllers are CE marked to the Low Voltage Directive (LVD). The LVD is a European Union directive regulating the construction and operation of electrical equipment that is not considered a medical device. These listings and certifications encompass the entire freezer system including the electronic controller.

MVE brand manufactured liquid nitrogen freezers covered in this manual are non-hazardous, open mouth vacuum insulated dewars. They are constructed of stainless steel and aluminum and specifically designed to hold liquid nitrogen. They are not subject to any pressure vessel codes as they are open to atmospheric pressure.

MVE liquid nitrogen containers are shipped empty without liquid nitrogen or any hazardous material from our factory. An MSDS is not available for the final formed and welded assembly. An MSDS on the stainless steel or aluminum alloys used is available but is not specific to the complete manufactured vessel.



3 Home Screen

3.1 Home Screen Information

The home screen displays the status and storage conditions of the freezer. The freezer's level and temperature performance are displayed continuously. The Header includes the assigned Freezer Name, Temperatures A&B, LN2 level, turn tray position indicator (if equipped), User Log In, Wi-Fi, Date and Time. The controller continuously displays the time and date on the top right-hand corner of the touch screen. The Alarm indicator bar turns red or yellow signaling an issue. Additionally, Temperature and LN2 Graphs can be viewed providing a convenient quick view of freezer performance. For added convenience, when logged in with admin rights, the icons below the temp A&B and level display allow quick access to setpoints. Touching the lower middle section up/down arrow key will show additional features, such as the *Unlock Lid, *Lid Sensor, Autofill, Scheduled Fill, and Info pages (*If so equipped).

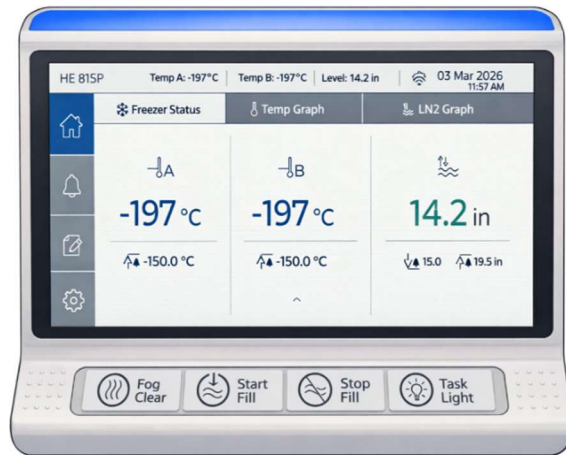

Figure 1. Home Screen

3.2 Home Screen Temperature & LN2 Level Hot Keys

The controller provides Hot keys to quickly access Temperature and Level Setpoints from the Home screen if the user is logged in and has admin level access. Touch the Icons located under the Temperature or Level display to change the alarm set points.



Touch to access setpoints. (Must be logged in)

Figure 2. Temp A & B Level (Hot Keys)



3.3 Home Screen LN2 Autofill & Scheduled Fill Hot Keys.

Touch the up-arrow key at the middle lower area of the screen to access additional menus.

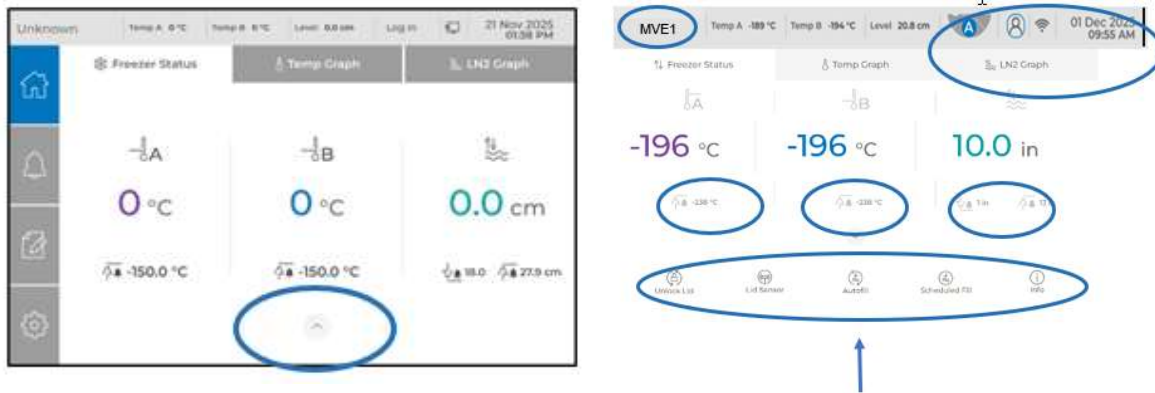

Figure 3. Home Hot Keys

3.4 Freezer Info Hot Key

Touch the Info key to access freezer information



Figure 4. Freezer Information Page

The CryoVerse™ Connect Controller Information screen displays all related serial numbers and technical service contact information.

- Freezer Serial Number
- Freezer Model Number
- Controller Serial Number
- Display Serial Number
- Software Version
- Firmware Version
- Technical Service Number
- Technical Service Email



3.5 Temp A & B LN2 level Graphs

From the Home screen, you can view Temp A & B and LN2 Level Graphs. Press Temp Graph to view temperature A & B graphs.



Figure 5. Temp & LN2 Graph Access Keys

Temp A or B can be enabled or disabled to view each graph individually. Date ranges can be selected by Day, Week, Month, or Range.

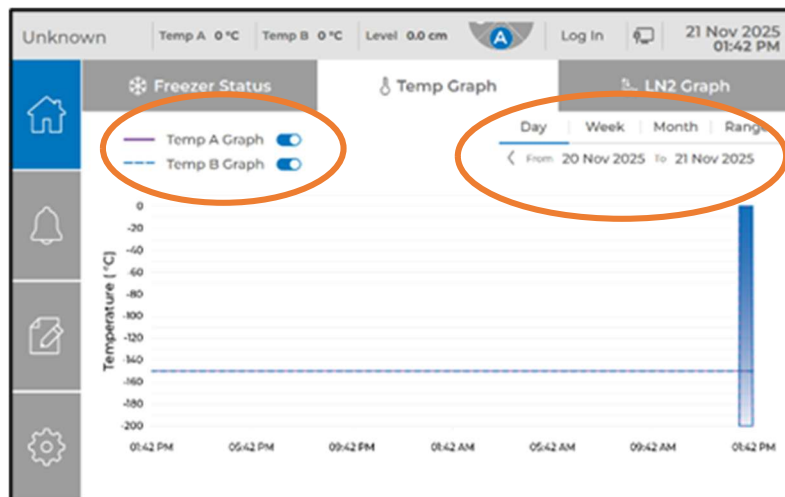

Figure 6. Temp A & B Graph & Range Settings



The screen below shows the Range selected from December 11 to December 13, 2024.

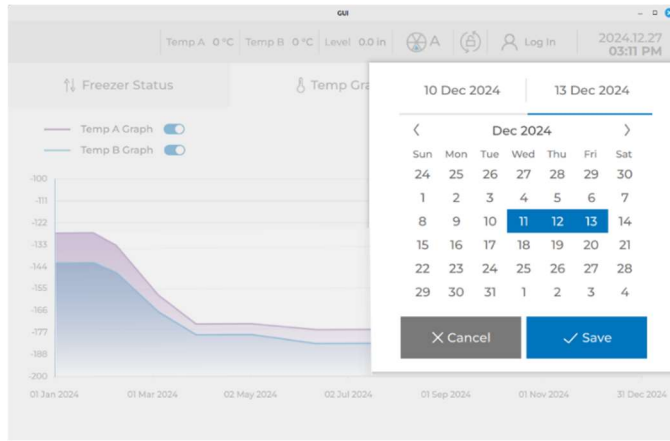

Figure 7. Temp Graph Range Selected

Temp A & B Graphs are shown below.

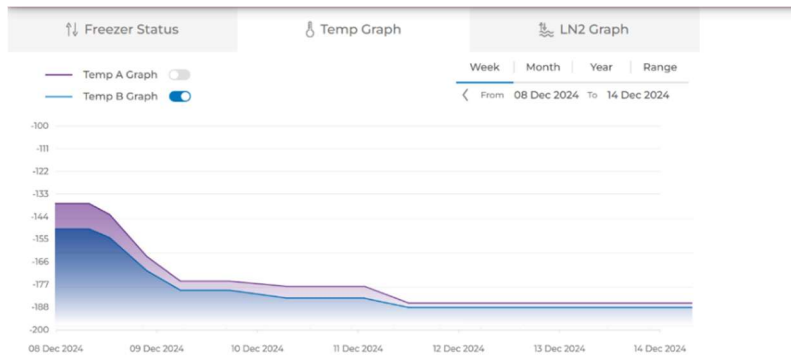

Figure 8. Temp A&B Graph Display

The LN2 level graph is shown below.

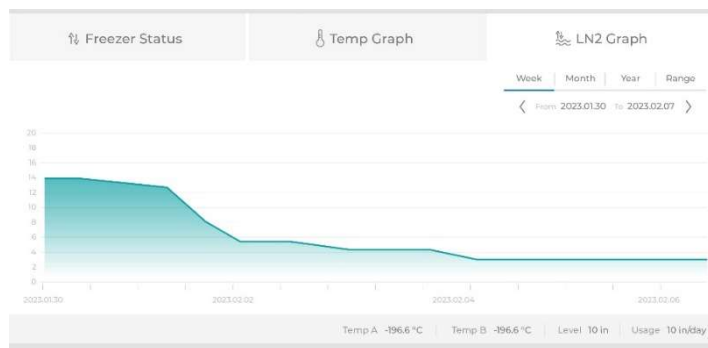

Figure 9. LN2 Graph Display



4 Logging in and Setting up Usernames and Passwords

4.1 Log in & Setting up Usernames & Passwords

The CryoVerse™ Connect controller is shipped from the factory with a default “Admin” and a new password will need to be created. Refer to the Initial Pre-Setup section of this manual.

The “Fog Clear”, “Fill Stop”, “Task Light” and the “Slide to Silence Alarm”, the Home, Alarm, and Data screens can be accessed without logging in. Although the Data screen’s Journal, Event, and Data screens can be viewed, you must log in to Export data, add journals or navigate to any Settings tabs. Once logged in, set up a new administrator name and password. Save the new administrator’s Name and the new Password in a secure location for later reference.

4.2 About Usernames & Passwords

The CryoVerse™ Connect controller provides a secured Log in. By default, you are the “Admin”. The password requirement is any 8 characters, alpha or numeric, upper or lower case.

- Admin: Can access all menus and reset all other admin and user passwords.
- Users: Can access some menus except Temp, Level, General, Advanced, Network, and Accessories Menus.
- Distributor: Can access all menus but cannot access Users in the Advanced Menu.

Once logged in, additional Admins, Distributor & Users can be added. If the password is forgotten and if you are still logged in as admin or distributor, press **“Factory Reset”**, as this will reset the controller and will bring you to the initial Setup Screen.. Reenter a new password. If you are logged out and have forgotten the password, contact the admin of the CryoVerse™ Connect controller to reset your password or contact MVE Technical Service (1-844-MVE-CRYO) and follow their instructions to reset the admin and password. Follow the instructions to log in.

1. Press the Login Icon on the Home screen



Figure 10. Log In Icon



2. Select Admin and enter the password.



Figure 11. Log In Screens

3. Enter the password, using the Up arrow key for Caps. Press Hide/Show Icon to view the password if desired.

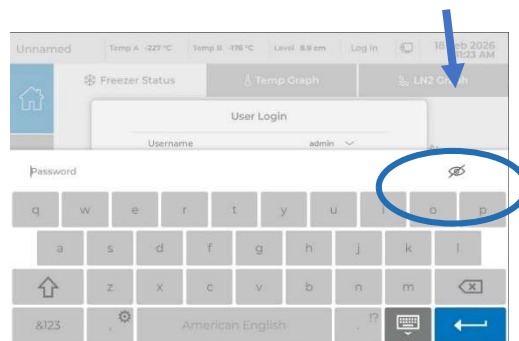

Figure 12. Intuitive Keypad

4. Press the Log In button after entering the password.



Figure 13. Log In Button



- Once you're logged in as an admin to setup or add users, press Settings, then Advanced, and press Users. Press "Add User"



Figure 14. Add User Screen

- Press "Level" to set user access level as an Admin, Distributor, or User, then press Save. To complete the user setup process, enter information all user fields.

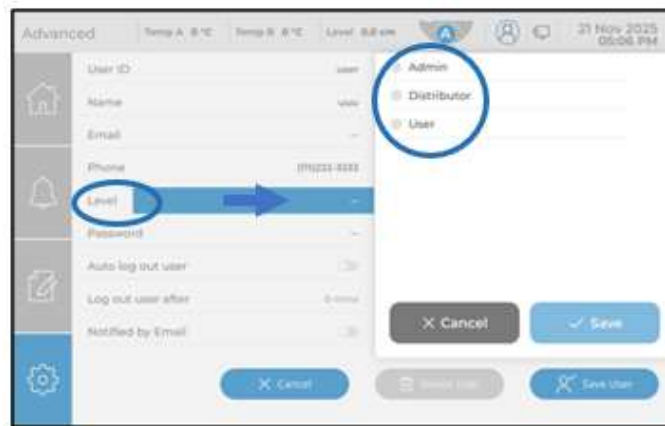

Figure 15. Select Admin, Distributor, or User

- To Delete a user, touch the icon next to the User ID

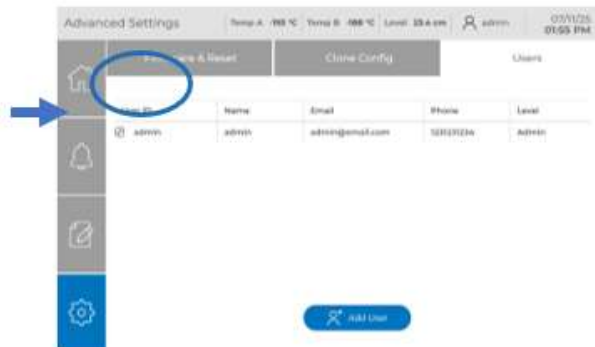

Figure 16. Select User



8. Press Delete User. A message will display to confirm; press Cancel or Delete.

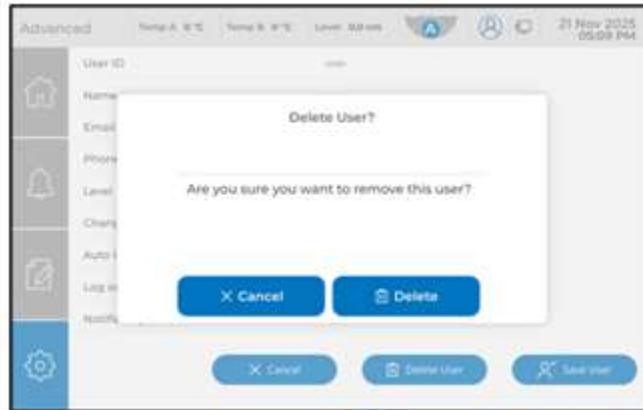

Figure 17. Delete User

9. Forgot Passcode

In the event you forget the admin password, contact your distributor. You can also contact MVE Technical service (1-844-MVE-CRYO) and follow their instructions to reset the admin password.

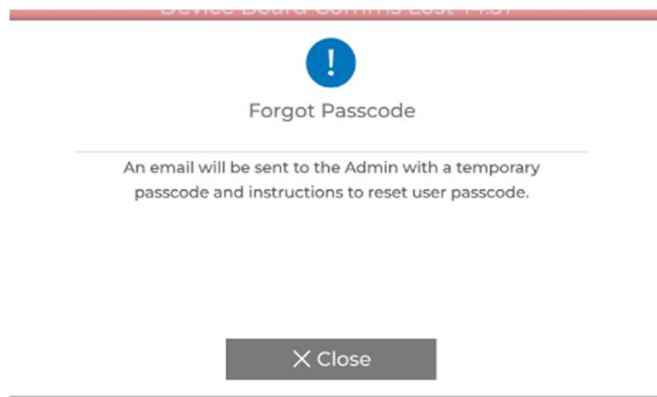

Figure 18. Forgot Password Information



5 Alarms Screen

5.1 Silence Alarm (Mute) Slide to Silence Alarm

The alarm can be silenced for 30 minutes by touching the “Slide to Silence Alarm” bar. Once it is silenced the alarm status screen will appear showing what alarm was triggered. The CryoVerse™ Connect Controller is **not equipped to disable the audible alarm**, only silence the alarm for 30 min.



Figure 19. Alarm Slide to Silence Bar

The “Alarms Screen” displays the alarm that is active in Red (Critical) or Yellow (Non-Critical) alarms. Once the alarm is muted the Alarm Screen will pop up on the display overriding any screen that was being viewed. This feature is to provide 100% confirmation to the user that an alarm has been triggered and cannot be ignored. Touch the Red or Yellow Active alarm to view the details of the alarm. The red or yellow bar at the top of the screen will also show a message of what alarm(s) are active. MVE strongly recommends that users do not disconnect the A/C power source from the controller when any alarm is active. Always contact your MVE Distributor for any alarms.

5.2 Alarms Screen

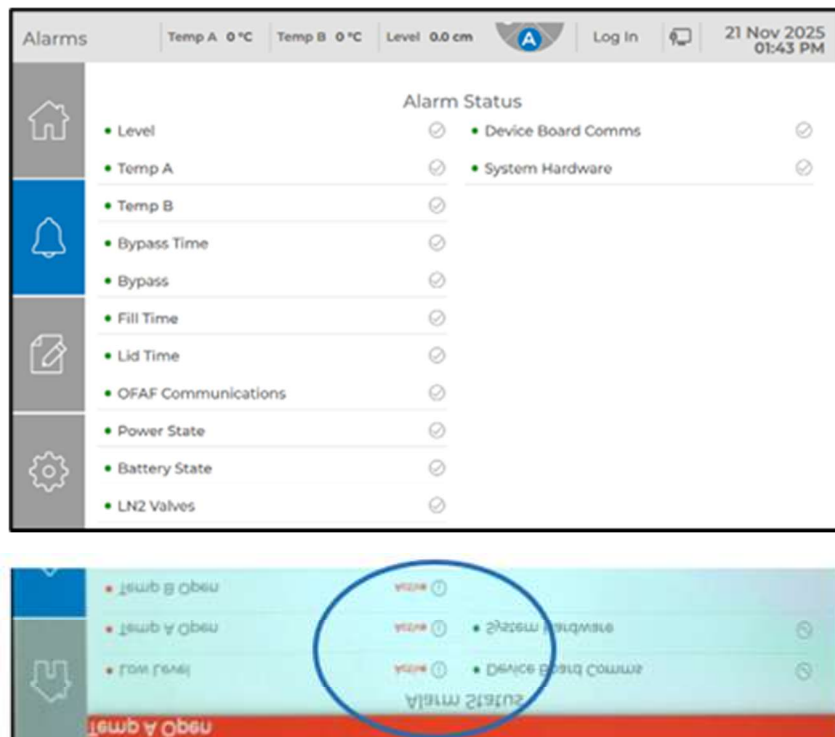

Figure 20. Alarm Status Screen



Under normal operations, if the controller alarms the alarm must be silenced manually every 30 minutes. The controller will continue to alarm until the alarm condition has been resolved. The CryoVerse™ Connect Controller is **not equipped to disable the audible alarm**, only silence the alarm for 30 min.



Figure 21. Alarm Slide to Silence Bar

The only exception is during the first initial setup. There are no audible or visual alarms during the initial setup to minimize nuisance during the first initial setup. Refer to the CryoVerse™ Connect Initial Pre-Setup (Quick Start & Initial Fill) of this technical manual for details on certain alarm behavioral conditions that occur only during the start of an initial fill cycle.

The CryoVerse™ Connect Controller alarms are accompanied by an audible alarm, visual alerts on the screen and a flashing, rotating alarm beacon. The global remote alarm contacts will switch to either N/C or N/O alarm state. If the triggered alarm is one of the four specified discrete alarms, then that contact will also switch to alarm state.

To mute and clear an alarm, first touch the Slide to Silence Alarm and then correct the condition of that alarm. If the alarm condition is still present, touching the Slide to Silence Alarm will only silence the audible alarm for 30 minutes. The condition must be corrected to clear the alarm. Always contact your MVE Distributor for any alarms.



5.3 Alarm Descriptions Critical & Non-Critical

Critical Alarm (Red Warnings):

- Temperature A&B High Alarms
- High/Low LN2 level alarms
- Lid Time Alarm
- Stuck Valve alarm
- Power Loss alarm (Alarm will sound immediately once AC power is disconnected)

Non-Critical Alarms (Yellow Alarms):

- Fill Time alarms*

*Critical Note the controller will not auto fill until this alarm has been corrected or silenced; therefore, if no one is onsite to physically MUTE or correct this condition for days, the freezer will not auto fill. There's the potential, depending on days, and however unlikely, with no LN2 being added, the freezer's temperature may warm up.

*Always contact your MVE Distributor for any alarms.

MVE has incorporated built in protection/redundancy circuits that if the freezer is not filling for days the temperature A & B high alarm will activate (Critical Alarm - See above).

- Gas Bypass Alarms*

(Note the controller will not auto fill until this alarm has been corrected or muted, see above notes)

Some of the common issues that the controller should guide users on are:

- Fill time alarms and why the freezer is no longer filling. (Or takes longer to fill)
- Why am I getting a usage alarm/high usage. (Available in the Service Module, next firmware)
- A pop-up reminder for annual service prompting the technician to fill in the notes section. (Available in the Service Module, next firmware)
- How to properly check the LN2 level with the measuring stick.
- LN2 level calibration (Use Level Off-Set) (Available in the Service Module, next firmware)
- Temp A,B & Bypass Sensor calibration (Available in the Service Module, next firmware)

Alarms requiring testing

- Fill Time
- High Temp A & B
- LN2 Low and High level
- Alarm Relays (Global & Discrete Contacts)

**Table 2. Alarm Descriptions**

Alarm Display	Description
High Temp A	Temperature A is reading at or above the Temp A High Alarm Setting. When disabled, there will be no visible or audible alarm indication. The alarm event code will continue to be recorded in the internal data log.
High Temp B	Temperature B is reading at or above the Temp B High Alarm Setting. When disabled, there will be no visible or audible alarm indication. The alarm event code will continue to be recorded in the internal data log.
High Level	LN2 level is at or above the High-Level Alarm setting
Low Level	LN2 level is at or below the Low-Level Alarm setting
Fill Time	Fill cycle has not completed within the Maximum Fill Time setting (Auto fill is disabled until this alarm is cleared)
Inlet/Bypass Time Alarm	Hot Gas Bypass cycle has not completed within the Bypass Alarm Time Delay setting (Once the subsequent fill has ended, auto fill will be disabled until this alarm is cleared)
Low Battery	Backup Battery voltage has dropped below 21 VDC
Power Loss	The CryoVerse™ Connect Controller's main power has been disconnected, and it is running on battery power. This will alarm immediately.

5.4 Alarm Beacon Light Descriptions Critical & Non-Critical

With AC Power:

1. Slow rotating blue & white = Idle
2. Rapid rotating blue & white = filling
3. Blinking red = critical alarm
4. Rotating red = critical alarm while filling
5. Blinking yellow = non-critical alarm
6. Rotating yellow = non-critical alarm while filling
7. Purple = software update

Without AC power, running on backup battery:

Two red LEDs and reduced screen brightness



6 Journal, Event, & Data Tabs

The CryoVerse Connect controllers are equipped with the ability to add journals, view events and data. Touch the Data Tab to access Journal, Event and Data. The default page when accessing this menu will be the Journal Tab. Must be logged in.

6.1 Journal Tab

Journal features are a method to write your notes or any other pertinent data you think is important. It is good practice to keep track of occurrences.

1. Touch “Add Entry” to enter a journal. You can also Export journals to a USB Thumb drive.

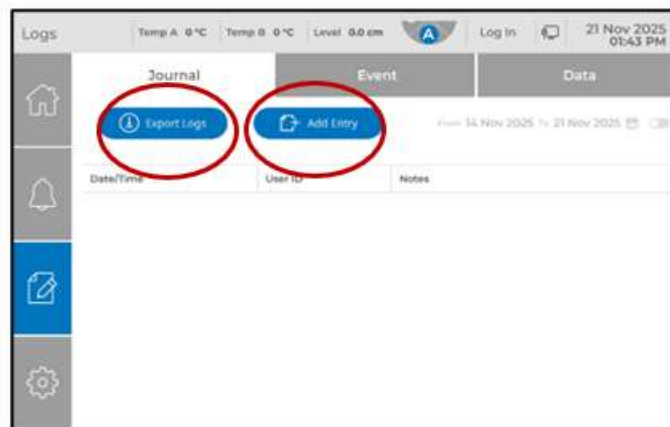

Figure 22. Journal Tab

2. Use the keyboard to enter your information. Then press Enter.

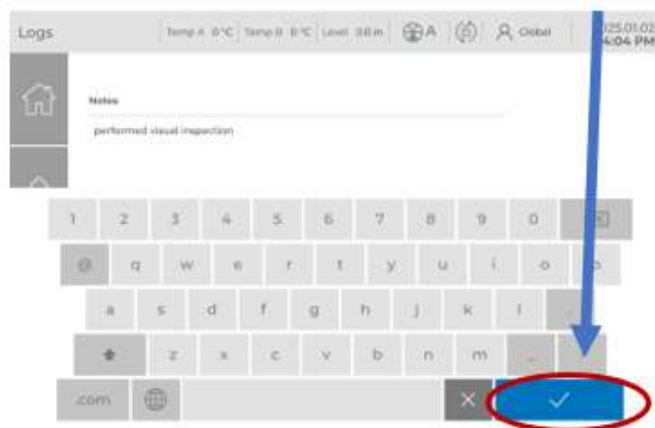

Figure 23. Intuitive Keypad



3. Touch Cancel, Save or Edit Log. When the journal entry is saved it can be viewed on the screen. The journal entry can also be edited.

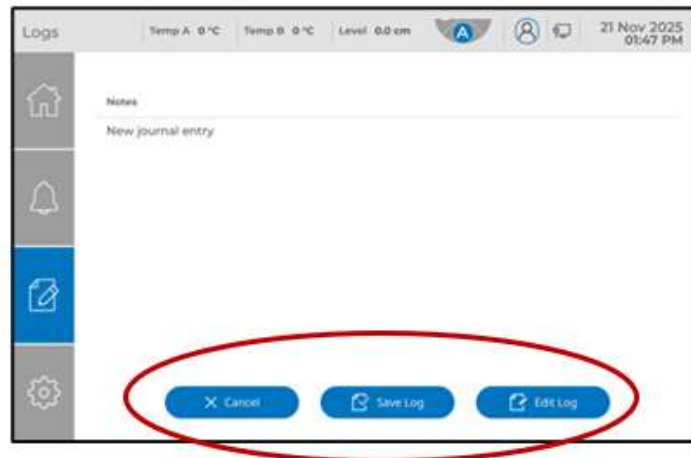

Figure 24. Journal Cancel, Save & Edit Log

6.2 Event Tab

In the Event tab, you can view the Event records/logs from any user interaction. You can Export events to a USB Thumb drive. Instructions are as follows:

1. Touch Export Events

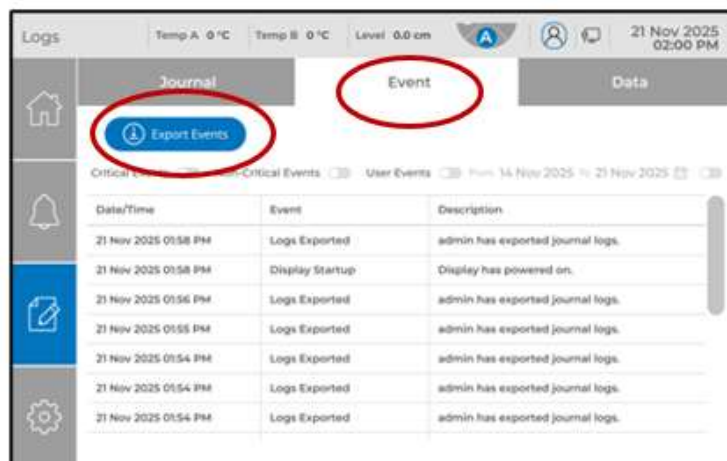

Figure 25. Event Tab



2. Select Event Range by date

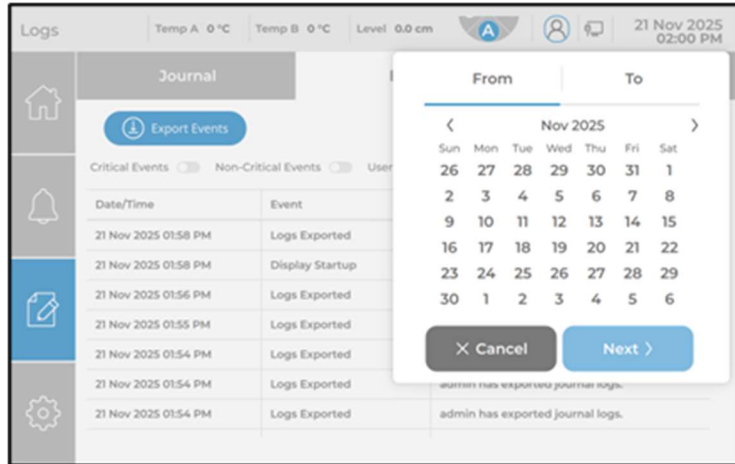

Figure 26. Event Range Setting

3. Select USB or send via Email and press Next.

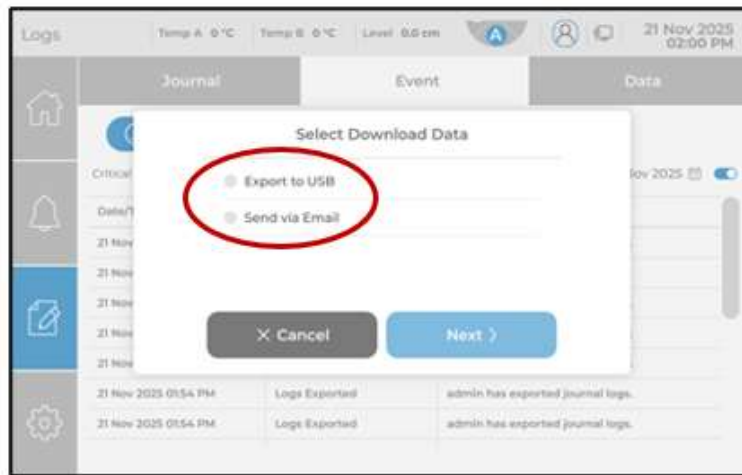

Figure 27. Event Download Tab



6.3 Data Tab

The Data Tab logs Temp A, B, and Level conditions. You can Export Data to a USB Thumb drive. Date ranges can be selected touching enabling the calendar tab.

1. Enable the calendar tab.



Figure 28. Data Tab

2. Select date range. Only dates selected will be displayed and exported to the USB Thumb drive.

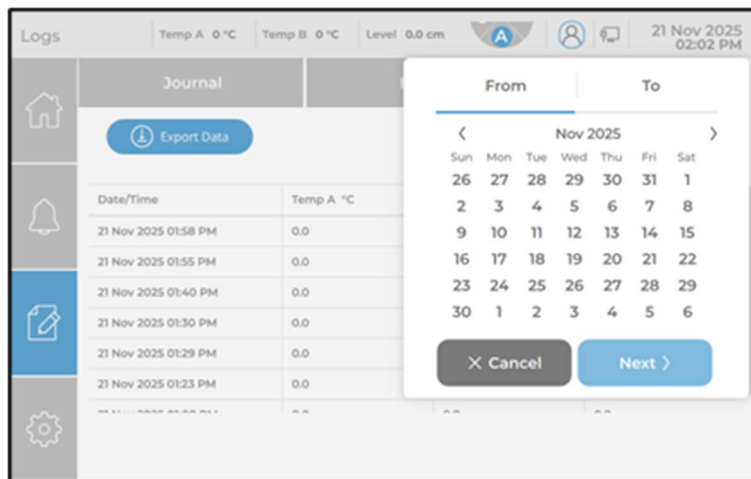

Figure 29. Data Range Tab



7 Settings Menu (Overview)

After Logging in press the Settings Icon  to access the Settings Menu.

The freezer's parameters can be adjusted by navigating to the Settings tab. The Settings Menu provides access to the Temperature, Liquid Level, General, Advanced, Display & Output, Network, Accessories, and Licenses Menus. You can also press the Home, Alarm, and Data buttons to access these tabs directly. The Settings menu is the primary source to access all controller settings. You must be logged in.



Figure 30. Settings Screen



8 Temperature, Inlet/Bypass & Stuck Valve Alarm Settings

8.1 Temperature A & B Alarm Settings

1. From the Settings screen touch Temperature to adjust Temperature A, B, and Inlet (Bypass) Alarm thresholds. There's also quick access to Temp A and B setpoints from the Home screen.

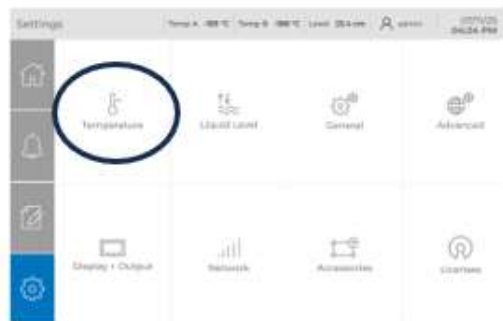

Figure 31. Temperature Settings

2. Adjust Temperature A or B Alarm thresholds by pressing the value numeric value.



3. Press the arrow key to view “Range” allowable for min/max thresholds.





8.2 Temperature Inlet/Bypass & Stuck Valve Alarm Settings



8.3 Temperature A & B, Inlet/Bypass Sensor Calibration

Available in the next firmware.

8.4 Temperature A & B, High Alarm Test

Note: At this time Temperature A, B & Inlet/Bypass sensor single/dual point calibration, High Temp alarm test, and LN2 Temperature Saturation settings are not supported.

8.5 Temperature Unit of Measure (UOM) Settings

Press Settings and then press Display and Output to navigate to the UOM settings to change unit of measure.

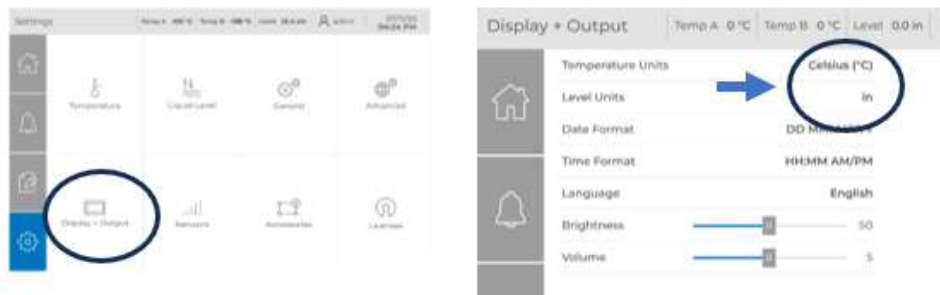

8.6 Liquid Nitrogen Saturation Temperature Adjustment

The LN2 saturation temperature is altitude dependent. The default LN2 saturation temperature is -195.8°C (-320.4°F, 77.4 K). This value is accurate for altitudes ranging from sea level to 500 feet (152 m). For the appropriate saturation temperature, refer to the Table showing LN2 Saturation Temperatures.



Table 3. LN2 Saturation Temp vs. Altitude

Altitude		Temperature	
Feet	Meters	°C	°F
Sea Level - 500	Sea Level - 152	-195.8	-320.4
501 - 1000	152 - 305	-196.0	-320.7
1000 - 1500	305 - 457	-196.2	-321.1
1501 - 2000	457 - 610	-196.4	-321.5
2001 - 3000	610 - 915	-196.6	-321.9
3001 - 4000	915 - 1220	-196.9	-322.4
4001 - 5000	1220 - 1524	-197.2	-322.9
5001 - 6000	1524 - 1829	-197.5	-323.5
6001 - 7000	1829 - 2134	-197.8	-324.0
7001 - 8000	2134 - 2439	-198.1	-324.6
8001 - 9000	2439 - 2744	-198.4	-325.1
9001 - 10000	2744 - 3049	-198.7	-325.7



9 Liquid Nitrogen Level & Alarm Setpoints

The Liquid Level specifications for the level differential pressure range are +/- 0.5 inches (1.3cm). Although the controller can be set to a minimum of 0.5 inches (12.7cm) between each of the level setpoints, to minimize nuisance alarms there should be a minimum of 1-inch (2.5cm) span between each setpoints and the corresponding alarm threshold. We recommend a 2-inch (5cm) span between the High and Low level setpoints and adding or subtracting 1-inch (2.5cm) to level setpoints for the High and Low-Level Alarm thresholds, respectively.

For example, if the Low-Level Setpoint is set to 5.0 inches (12.7cm), then the Low-Level alarm threshold should be set to 4.0 inches (10.1 cm). If the High level setpoint is 7 inches (17.8cm) then the High-Level Alarm threshold should be set to 8 inches (20.3cm). The user must be logged in with admin or distributor privileges to change the level and alarm thresholds.

9.1 Adjusting Level and Alarm Setpoints

1. From the Settings screen press Liquid Level. There's also quick access to level setpoints from the Home screen.

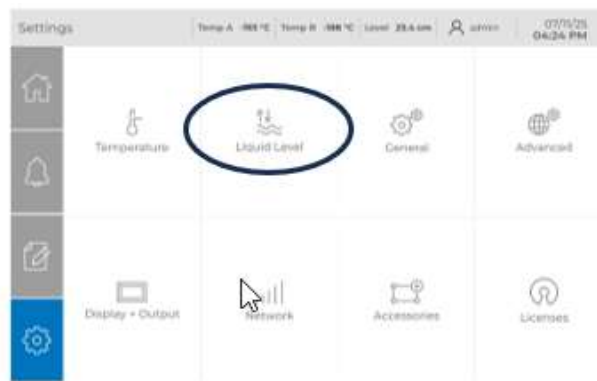

Figure 32. Liquid Level Settings

2. In the LN2 General menu, adjust the LN2 Level and Alarm Setpoints by touching each value shown by the arrow below.



Figure 33. Liquid Level Setpoints



10 Liquid Nitrogen Advanced Fill Settings Menu

The Advanced LN2 menu provides access to enable/disable Manual Fill without logging in, Auto Fill Control, setup Scheduled Fill (Timed Filling), change the Max Fill Time and perform the Liquid Level Offset Calibration.

10.1 Allow Manual Fill (Without Logging in)

The “Allow Manual Fill control without logging in”, can be enabled or disabled in this menu. When enabled the Start Fill button can be pressed without logging in. The event log will record “Unknown” User has started a fill.

10.2 Auto Fill Control

The Auto Fill control can be enabled or disabled in this menu.

10.3 Max Fill Time

The Max Fill time can be set within a range of 1-240 min

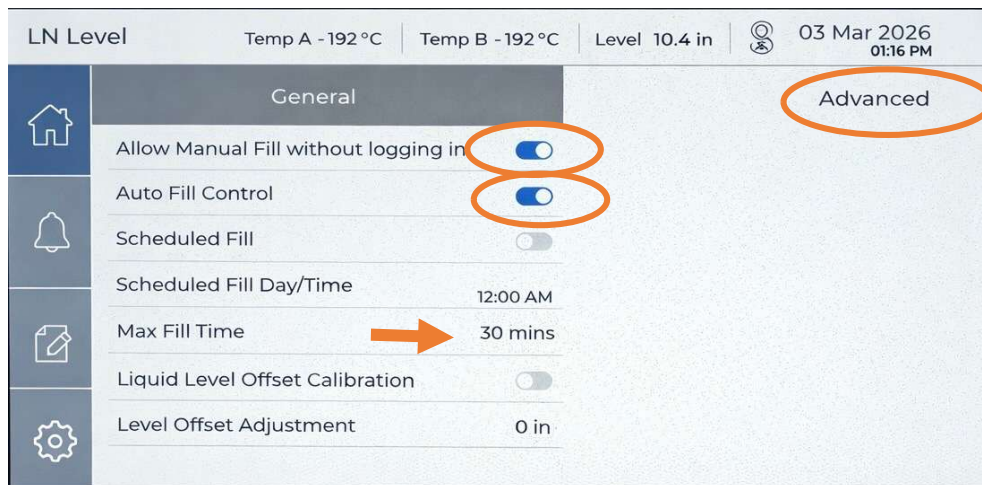

Figure 34. Advanced Fill Settings



10.4 Scheduled Fill

The Scheduled Fill allows the freezer to auto fill on a specific day(s) and at a specific time. Even if the LN2 level in a freezer is above its Low Level Setpoint, the controller will initiate a fill and top off the freezer. The controller will not fill at or above the High Level Setpoint. Auto Fill Control must be enabled. If the Stop Fill button is manually pressed the CryoVerse™ Connect controller's restricted idle disables the autofill for 10 minutes.

The screen below is an example where the Scheduled Fill Day/Time is set to M, T, W, TH, F. The highlighted days in blue show that the freezer will autofill each day of the week, except Saturday and Sunday. The Time to autofill is set to 07:15 AM.

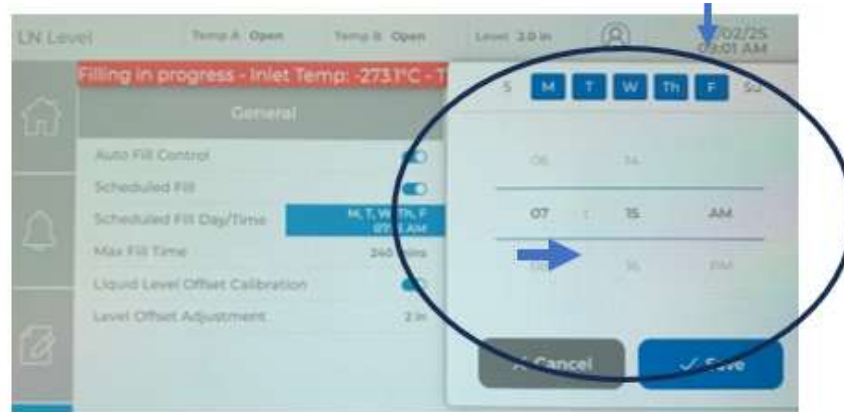

Figure 35. Scheduled Fill Time Settings

10.5 Liquid Level Calibration

The Liquid Level Offset Calibration must be Enabled to change the Level Offset Adjustment to match the physical level of Liquid Nitrogen in the freezer. Note: +2.00 will add 2 inches to the value displayed, whereas minus -2.00 will subtract 2 inches from the value displayed.

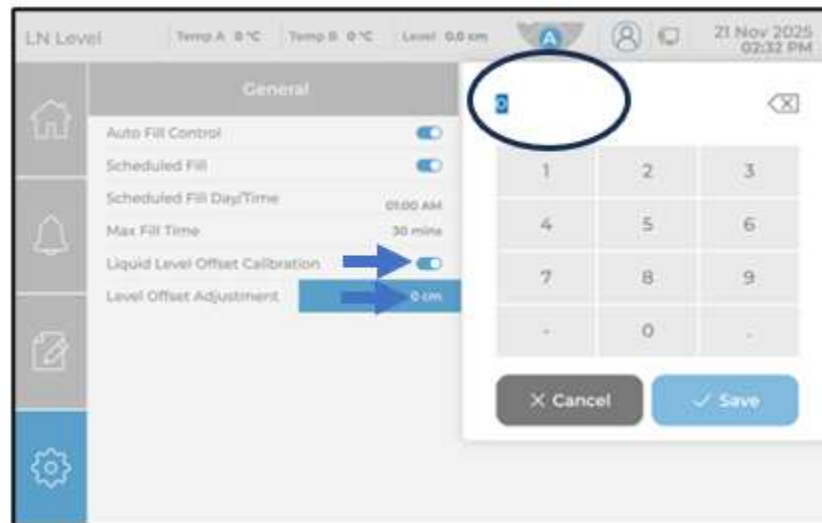

Figure 36. Advanced LN2 Screen



All new freezers equipped and shipped from the factory with the CryoVerse™ Connect controllers have been checked and adjusted at the factory. The liquid level should only be adjusted if the level displayed is suspected to be incorrect, if the controller has been replaced, or as part of a preventive maintenance service/schedule.

10.6 Restricted Idle

NOTE: Certain events can temporarily disable Auto Fill Control. Pressing “Stop Fill” will disable Auto Fill Control for 10 minutes. In the event of a Hot Gas Bypass Alarm or a Fill Time Alarm, Auto Fill Control will be disabled until the respective alarm is cleared by pressing “Slide to Silence Alarm” or restarting the controller.

Overfill Protection:

The overfill protection will prevent an automatic fill if the LN2 level reading is 0 or if the level reading suddenly drops to 0. This prevents an overfill scenario in any situation where the CryoVerse™ Connect controller loses its ability to measure the LN2 level.



CAUTION: Always wear protective gloves, clothing and face shield when handling LN2. Refer to the Safety section of this manual.



11 Liquid Nitrogen Level Dipstick Procedure

Once the Fill Cycle has completed allow liquid to equalize and insert dipstick; verify level to the controller level display. If necessary, change the level offset value (+ or -) to match the physical level of LN2. The CryoVerse™ Connect will continue to maintain LN2 levels and monitor temperatures A and B. Routinely monitor and verify freezer LN2 level and ensure there is sufficient LN2 supply and adequate pressure.

The CryoVerse™ Connect controller has a restricted idle that disables the autofill function for 10 minutes after a fill cycle ends or is manually stopped.

11.1 Dipstick Procedure

1. Open or remove the freezer lid to access the interior storage space.
2. Hold the dip stick vertically with the 0.0-inch end pointed down.
3. Lower the dip stick into the turn tray's LN2 dip stick channel. Some LN2 boiling will occur around the meter dip stick.
4. Leave the dip stick in the LN2 for approximately 5 to 8 seconds.
5. Remove the dip stick from the liquid and immediately wave it back and forth in the air. A distinct frost line will begin to develop as moisture in the air condenses on the dip stick predominately where it was submerged.
6. Subtract 0.5 inches (1.3 cm) from the observed frost line to account for the LN2 boiling up around the dip stick while it was submerged. This resultant level measurement represents the actual liquid level inside the freezer. Once you have obtained the measured level, if necessary, proceed to the liquid level offset calibration adjustment.



The figure above is a Dip stick example. The resultant measured level would be 7.5 inches after subtracting 0.5 inches from the 8.0 inch frost line to account for the LN2 boiling.

Note: LN2 liquid at or above turn tray height will rise higher in the dip stick channel.



Figure 37. MVE Dipstick Channel Location



11.2 Overfill Protection

The CryoVerse™ Connect Controller has a built-in overfill protection circuit that will prevent an automatic fill if the LN2 level reading is zero “0” or if the level reading suddenly drops to 0. This prevents an overfill scenario in any situation where the controller loses its ability to measure the LN2 level. Always verify that the vinyl tube is connected.

11.3 Restricted Idle Protection

Note that pressing Stop Fill on the CryoVerse™ Connect will disable the “Automatic Fill”, function for 10 minutes. The controller has a built in restricted idle feature that is set for 10 minutes. Additionally, if the level suddenly drops to zero “0”, the controller will disable the “Automatic Fill” until the issue has been resolved. Note that manually pressing Start Fill will override this protection.

The CryoVerse™ Connect controller has a restricted idle feature and will disable the autofill function for 10 minutes after auto filling is complete or manually stopped.

11.4 Liquid Nitrogen Usage

Liquid usage is not currently supported.

11.5 OFAF (One Fill All Fill) Settings

OFAF networking allows multiple controllers to be linked together such that all freezers will fill whenever a networked controller calls for a fill. When multiple freezers are connected to a common supply source, it is advantageous to fill all freezers at the same time. LN2 transfer losses are significantly reduced by filling all networked freezers while the supply system is primed and cold. Using an OFAF network is more efficient than cooling the supply system every time an individual freezer fills. This approach is also more efficient than employing a keep-full / keep cold system.

An OFAF network can be configured in two modes: “Sequential” or “Simultaneous.” For both modes, when any controller in the network initiates a fill, the Master controller (OFAF ID 1) recognizes this and triggers all other controllers to initiate fills as well.

In Sequential OFAF mode, once the controller that initiated the first fill has reached its High Level Setpoint, the Master will trigger the freezer with the next sequential OFAF ID to fill until it reaches its High Level Setpoint. The Master will then trigger the freezer with the next sequential OFAF ID to fill and this process will continue until all freezers in the network including the Master have reached their High Level Setpoints.

In Simultaneous OFAF mode, when any controller initiates a fill and fills for at least 60 seconds, the Master will then broadcast a signal for all freezers, including itself, to begin filling. Each freezer will continue to fill until its High Level Setpoint is reached.

A user would select sequential OFAF over simultaneous if their supply system is not able to maintain the proper filling pressure while multiple freezers fill at the same time. Sequential



OFAF allows freezers to fill one at a time with a primed and cold supply system so that it is easier for the system to maintain the proper filling pressure.

This section describes how to adjust the two One Fill All Fill features. A group of CryoVerse™ Connect Controllers can be networked to coordinate fill cycles and reduce LN2 transfer losses. For locations with multiple freezers, this function will increase the filling efficiency and drastically reduce overall LN2 consumption. Sequential and simultaneous OFAF networks are possible.

MVE recommends setting up the CryoVerse™ Connect Controller as the Master in an OFAF network if planning to include the TEC3000's. See Settings below.

1. Enable Com Port and select Baud Rate, 9600 bps



Figure 38. Com 1 Settings

7. Set Mode to OFAF

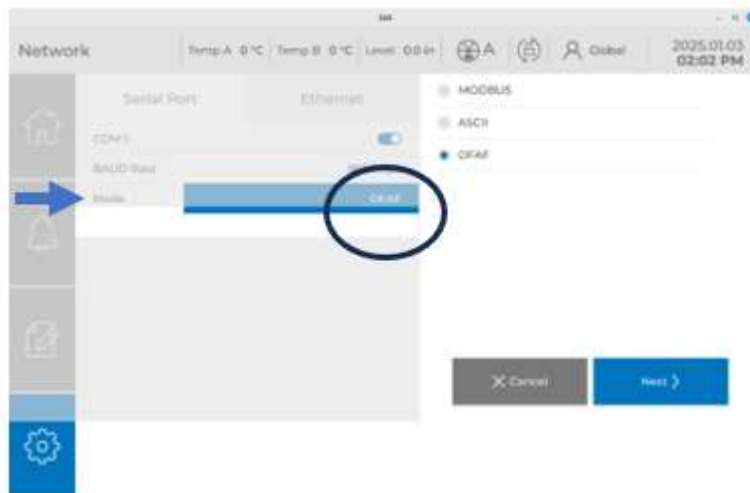

Figure 39. Baud Rate Selection

8. Select Master or Subordinate for additional controllers and enter OFAF ID

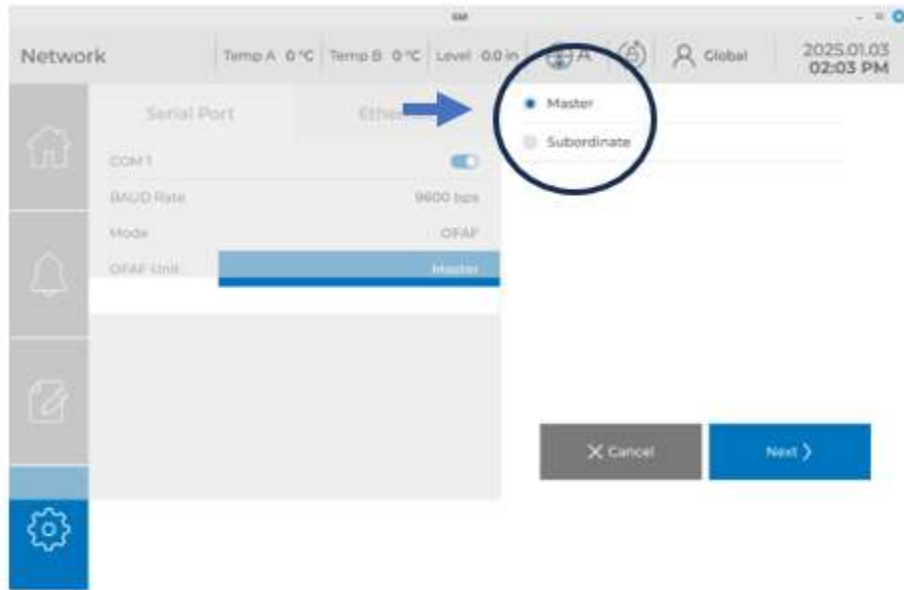

Figure 40. OFAF Settings

11.6 OFAF Cables & Setup

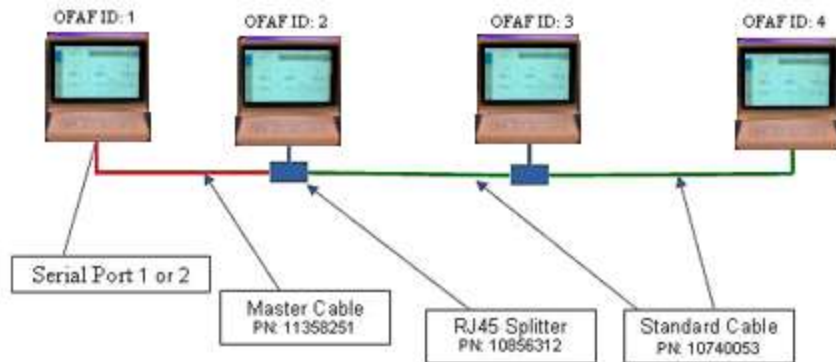

Figure 41. Typical OFAF network setup with four controllers

Part Number	Description	Qty Required
11358251	OFAF Master Cable	1
10740053	Standard CAT 5e Cable	# of controllers -2
10856312	RJ-45 Splitter	# of controllers -2

Note: Shielded cables should be used and the shield should be grounded where it connects to remote monitoring equipment or comm/networking equipment.



12 General Settings Menu

Press Settings, then General. The General Settings menu displays the Freezer Name, Synchronize Time with the Internet, Time Zone settings, set Language, change Logging Intervals, Sample Vision Calibration (Turn Tray ID-Letter Location), Freezer Product, Model, Freezer and Controller Serial numbers. Must be logged in.

12.1 Press Settings to Access General Settings

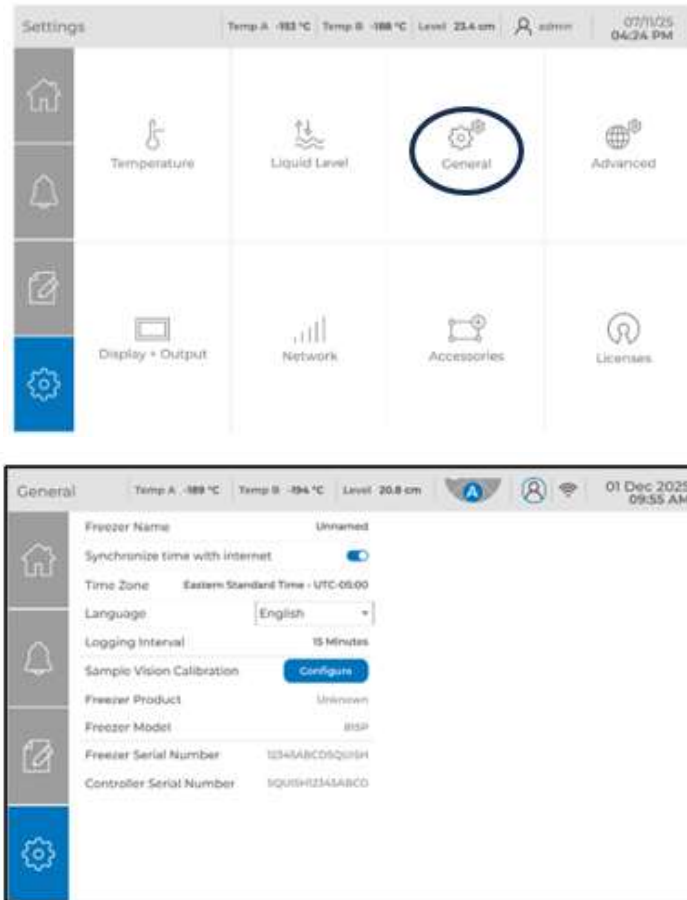

Figure 42. General Settings Screen



12.2 Freezer Name

Add or change the freezer name by touching on “Freezer Name”

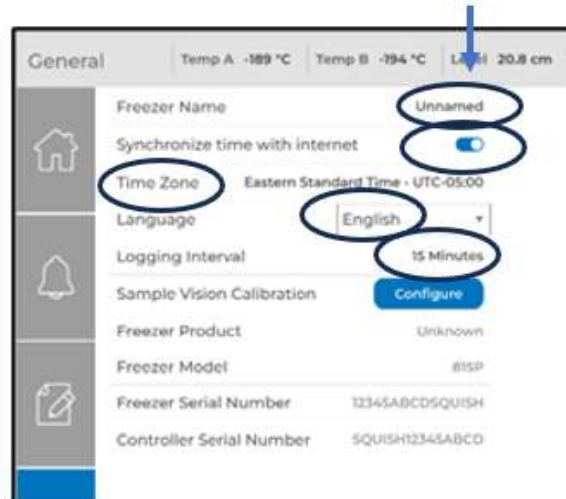

Figure 43. Freezer Name Location

12.3 Time, Date, Language, & Log Interval Settings

The CryoVerse™ Connect controller displays the Date & Time on the top right-hand corner of the screen. To adjust the Date and Time, synchronize time with the internet and change the Time Zone. Administrators have the option to synchronize time with the internet and adjust the Time Zone. The language can be changed from English to Simple Chinese.

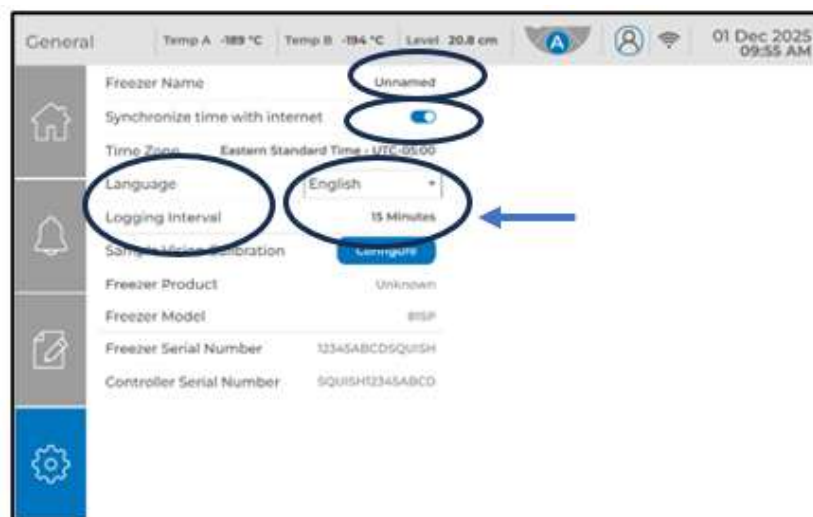

Figure 44. Date & Time Screen



12.4 Logging Interval

Change Log time interval (Range one to 15 minutes)

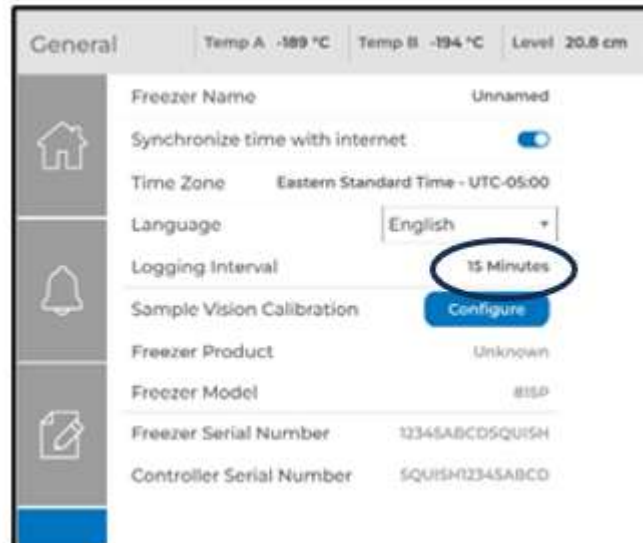

Figure 45. Logging Interval Settings

12.5 Freezer & Controller Serial Numbers

The Freezer Product, Model, Freezer and Controller Serial numbers are displayed

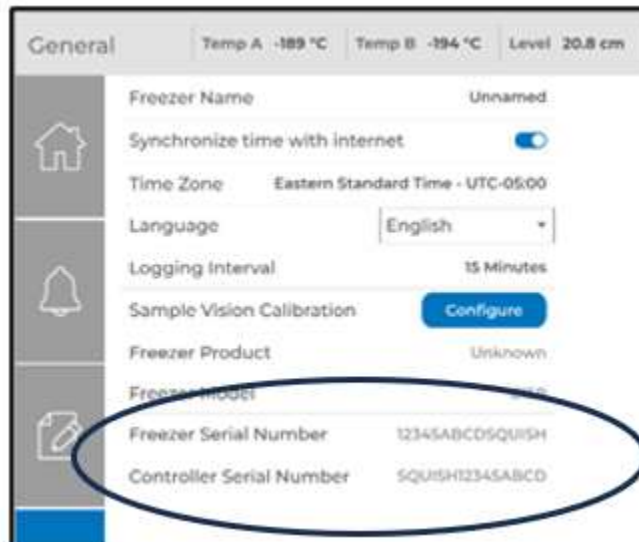

Figure 46. Product Serial Numbers



13 Advanced Settings Menu

13.1 Press Settings to Access Advanced Settings

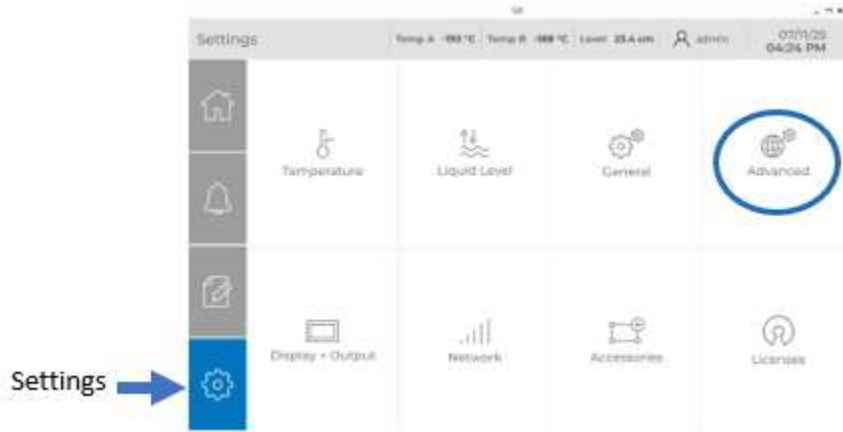

Figure 47. Advanced Settings

The Advanced Settings menu provides access to Firmware & Reset, Clone Configuration, Users, and *Notifications. Must be logged in with admin privileges.

13.2 Firmware, Restore Default, Factory Reset, & Restart Controller

The Firmware & Reset screen shows the Product, Software Version, Multiplexer Version, Firmware Version, OS Version, and when the Firmware and Software was last updated. This information is useful when requested by MVE Technical Service for troubleshooting. There are three keys at the bottom of the screen to, Update the Firmware, Restore to Defaults, and Restart the CryoVerse™ Connect Controller.

1. Press Update Firmware to Update

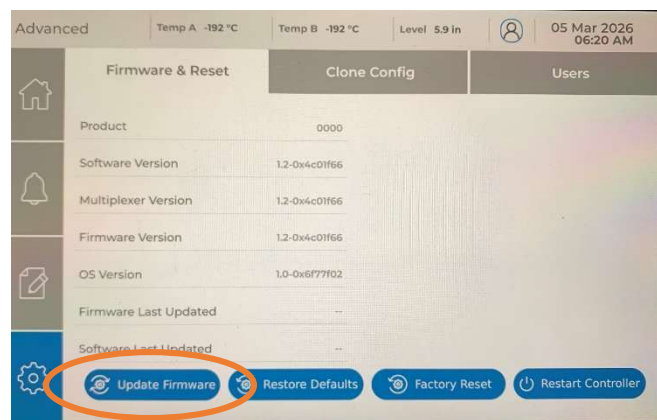

Figure 48. Update Firmware Selection



- The CryoVerse™ Connect Controller will search for the new firmware and update automatically. If there is no need for a firmware update the controller will display the message “No compatible firmware update detected”. Press Done to Exit.



Figure 49. Done Searching for Firmware

13.3 Restore To Defaults

To restore, press Restore Defaults. This process will keep the freezer name and keeps you logged in but will restore the CryoVerse Connect controller Temps and Levels back to factory defaults. Historical Journals, and Data will be lost but events will be retained. MVE recommends saving controller settings using the feature “Clone Config” before restoring to defaults.



Figure 50. Restore To Defaults



13.4 Factory Reset

Factory Reset will reset the entire controller’s settings back to original new factory settings and will bring you to the initial Setup Screen. Admin, Distributor, and Usernames and passwords will be lost. MVE recommends saving controller settings using the feature “Clone Config” before resetting including downloading Journal, Events, and Data as all information will be lost.

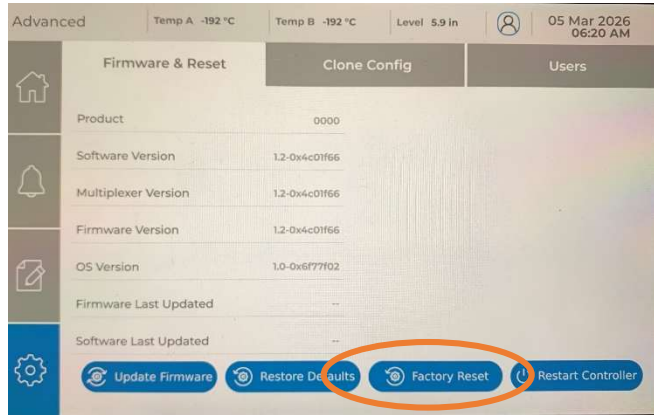

Figure 51. Factory Reset

13.5 CryoVerse Connect Controller Default Settings

The table below shows CryoVerse™ Connect’s factory default settings (Ver 1.2). These values are subject to change in subsequent firmware releases.

Table 4. CryoVerse™ Connect Default Settings

Name	Minimum	Default	Maximum	Note
ASCII Unit ID	1	1	9999	T3K=200
COM 1 Baud Rate	0 (9600)	0	2 (115200)	T3K=9600N81
COM 1 Config	0 (Off)	1 (ASCII)	3 (OFAF)	T3K=ASCII
Data Log Interval	1m	15m	15m	T3K=240m
Date Format	(0) MM/DD/YY	3 (DD MMM YYYY)	3	
Inlet/Bypass Alarm Time Delay	1m	5m	60m	
Fog Clear Time	1s	60s	300s	
Temp High Alarm Setpoint	-200.15C (73K)	-150.0 C (120K)	26.85C (300K)	
Inlet Temp Setpoint	-135C (138.15K)	-73C (200.15K)	-43C (230.15K)	
Temperature Unit	0 (F)	1 (C)	1	



Name	Minimum	Default	Maximum	Note
Lid Open Alarm Time Limit	0m	5m	360m	
Max Fill Time	30m	30m	240m	
Modbus Unit ID	1	1	9999	
OFAF Unit ID	1	1	300	
OFAF Subordinate Count	0	0	300	
Level Unit	0 (In)	1 (cm)	1 (cm)	
High Level Alarm Setpoint	15cm (6.0 in.)	20.3cm (8.0 in)	105cm (41 in)	
High Level Setpoint	10cm (4.0 in)	17.8cm (7.0 in)	100cm (39 in)	
Low Level Setpoint	5cm (2.0 in)	12.7cm (5 in)	95cm (37 in)	
Low Level Alarm Setpoint	3cm (1.2 in)	10.2cm (4 in)	90cm (35 in)	
Liquid Level Offset	-10.16cm (-4.0 in)	0	10.16cm (4.0 in)	

Name	Default	Note
Sample Vision	On	Stasis Models only
Auto Fill	On	
Scheduled Fill	Off	
Temp A Probe	On	
Temp B Probe	On	
Inlet/Hot Gas Bypass	Off	
Stuck Valve Detection	Off	
Level Offset	Off	
Lid Sensor	Off	Stasis Models only
Auto Fog Clear	Off	Stasis Models only
Lid Lock	Off	Stasis Models only
Auto Lock	On	
Email Server	Off	
Battery Backup	Off	
Inlet Bypass Menu	-	
Internet Connectivity	Off	



13.6 Restart Controller

Press to Restart Controller or Cancel.



Figure 52. Restart Controller Location

13.7 Clone Config Settings

The CryoVerse™ Connect Controller provides the convenience to “Export” Temperature, Level, and other settings onto an external USB Storage Device (USB Thumb Drive) and “Import” settings from the USB Thumbdrive to load settings. This convenient feature allows “Exporting & Importing” settings onto another CryoVerse™ Connect Controller. This saves time when installing and setting up multiple freezers of the same Model, i.e., MVE800’s, MVE1500’s, and MVE1800’s.

1. Press Export and insert USB Thumb drive.



Figure 53. Clone Config Settings



- System will detect a USB Storage Device and transfer controller settings. Press Cancel to stop the process. Once settings are transferred remove and insert USB Thumb drive into another CryoVerse™ Connect Controller. Touch Import to load settings.



Figure 54. USB Device Transfer or Cancel Location

14 Display & Output Settings

The Display and Output menu allows the changing of Temperature Units, Level Units, Date Format, Time Format, Language, and screen brightness. Must be logged in.

14.1 Press Settings to Access Display & Output

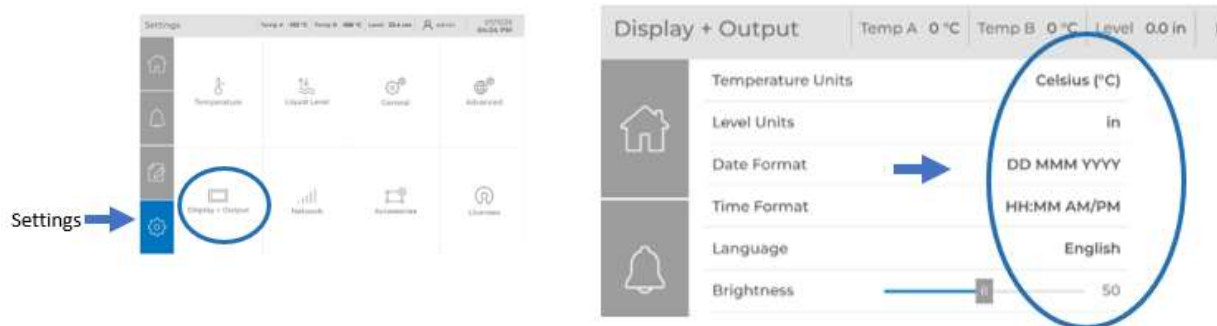

Figure 55. Unit of Measure Settings



1. Press Celsius to change temperature's unit of measure.

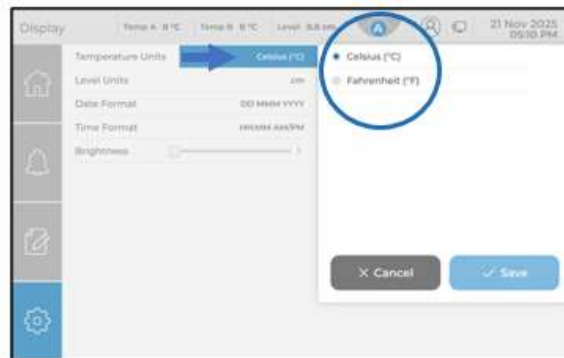

Figure 56. UOM Temp Settings

2. Touch Level Units to change Level Unit of measure

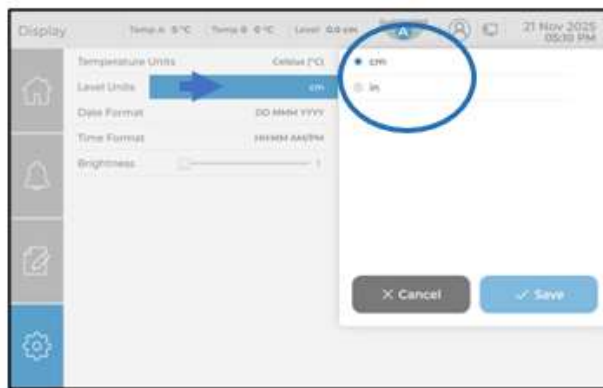

Figure 57. UOM LN2 Level Settings

3. Change Date Format

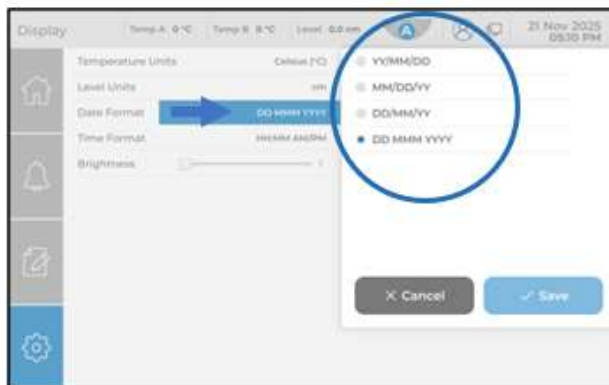

Figure 58. Date Format Settings Location



4. Change Time Format

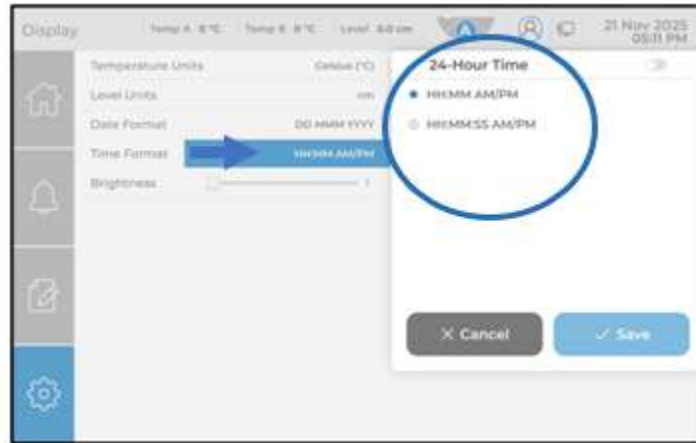

Figure 59. Hour Format Settings Location

5. Adjust the brightness of the screen by moving the slider, left to right.

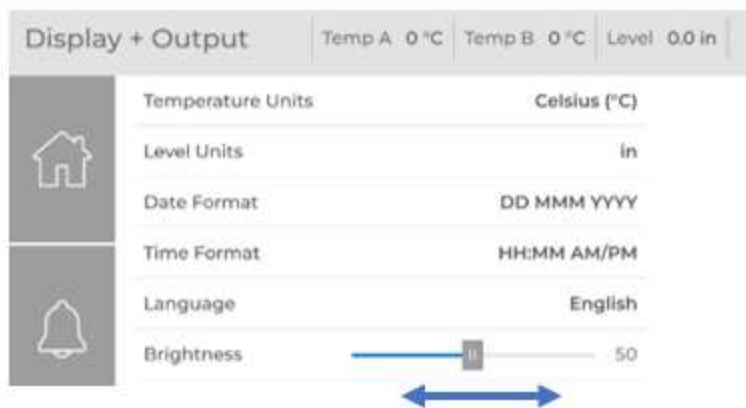

Figure 60. Screen Brightness



15 Network Settings

The Network Settings menu displays the Serial Port, Wi-Fi & Ethernet, and Email configurations.

15.1 Press Settings to Access Network Settings



Figure 61. Network Settings

1. Serial Port Settings can Enable/Disable COM1, change BAUD Rate, Mode, and change ASCII ID

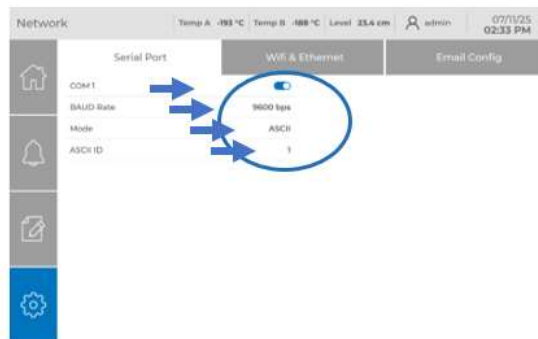

Figure 62. Com Port Location

15.2 Wi-Fi & Ethernet Settings

1. Touch Wi-Fi & Ethernet settings to set up a Network. Enable the Wi-Fi, and connect to a Wi-Fi network by touching “Configure”.

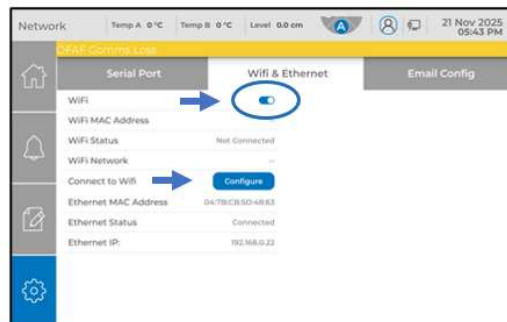



Figure 63. WIFI Location

2. The CryoVerse™ Connect Controller will scan for wireless networks, select a network from the drop-down box and enter security key if required.

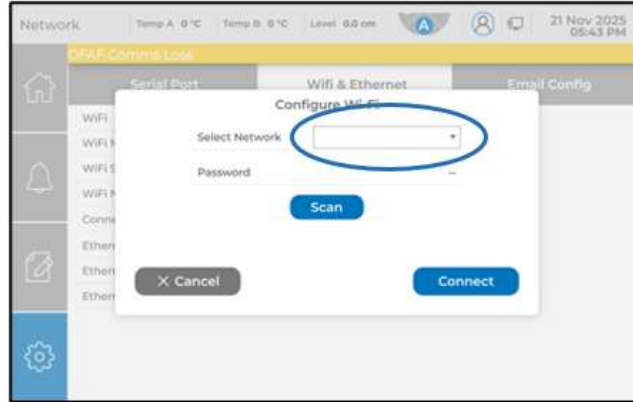

Figure 64. WIFI Network Name

3. Once connected to Wi-Fi, the Network name will appear in display.

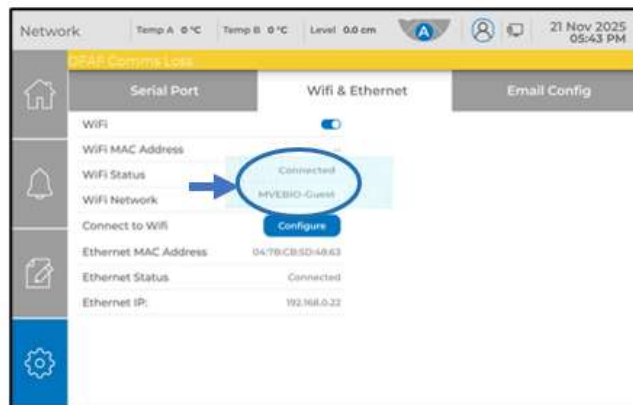

Figure 65. Network Name Detected



15.3 Email Config Settings

Email Config to set up a SMPT Host / SMPT Port, SSL, Import Certificate from USB, add Email Username and Password, add a Sender Email and touch Test to Send a Test Email. Once this is set up it can send email notifications, email Journals, Event and Data Logs.



Figure 66. Email Settings Location

1. Test Email Sent.
2. Note: Cell Notifications will be available in the Service Module, next firmware.

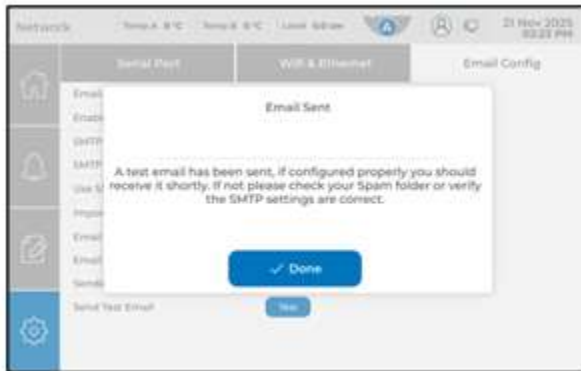

Figure 67. Email Notifications



3. Email Journals, Event, and Data Logs

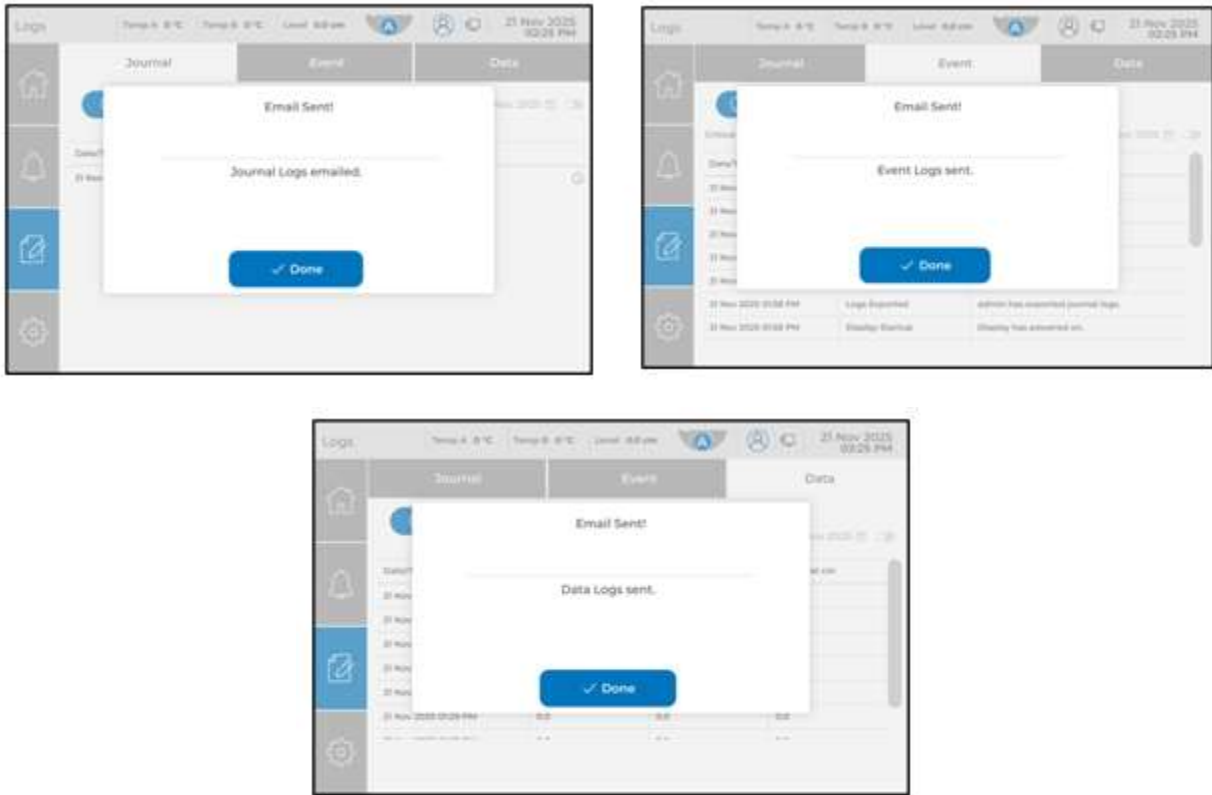

Figure 68. Email Journals, Event, and Data



16 Accessories Settings

The Accessories menu displays settings for the Lid Sensor, Auto Fog Clear, Auto Fog Clear Duration, and Lid Lock. These features are available only on Stasis Elite Models. Must be logged in.

16.1 Press Settings to access Accessories

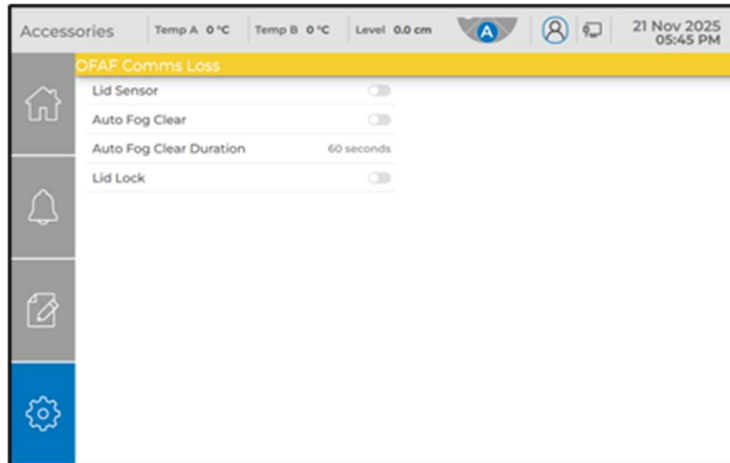

Figure 69. Accessories Location

17 Licenses

17.1 Touch Settings to Access Licenses Screen



Figure 70. License Location



18 MVE HE Freezer Product Information

This section provides an overview of MVE HE cryogenic freezers and their components. MVE offers a wide range of HE Freezers with CryoVerse™ Connect controllers that can accommodate a variety of inventory systems designed to meet all your cryogenic storage needs. Each freezer is individually made, double-walled, vacuum insulated stainless steel dewar designed to maintain temperature with minimal LN2 evaporation. There are no known contraindications for this device.

The MVE High Efficiency / Vapor Series freezers will maintain a vapor storage temperature of -190°C (+/- 5°C) when loaded with racks, with minimal LN2 evaporation while accommodating a wide variety of inventory systems. The CryoVerse™ Connect smart touchscreen controller can be repositioned for optimal access via its rotating screen and support. The removable plumbing cover provides easy service access to the plumbing assembly.

18.1 MVE HE Freezer Components

MVE HE Freezers are equipped with the following uniquely designed components:

- MVE CryoVerse™ Connect Controller
- Two tier step assembly (1500 and 1800 series freezers)
- Complete Plumbing Assembly
- AC to DC Power Supply
- Battery Backup Assembly

18.2 MVE HE Series Model Description

MVE offers several different models of HE series freezers, each of which offer specialized features and functionality. Each freezer has a descriptive name from which the highlighted features and performance specifications can be determined.

MVE (Series)(Capacity)(Turn-tray?) – (Temp?)(Full Auto?) – (Gas Bypass?) – (Battery Backup?)

Table 5. MVE Nomenclature Definitions

HE Series	MVE Freezer HE Series (i.e., 800, 1500, 1800)
Capacity	Approximate 1.2- or 2.0-mL vial capacity in thousands
Turn-tray	Shape of turn-tray dividers, MVE Stasis series only; P = pie-shaped, R = rectangular
Temp	“Top box” temperature rating, if applicable; *-190°C (+/- 5°C) *Loaded with racks
Full Auto	AF = Automatic Fill
Gas Bypass	GB = Hot Gas Bypass
Battery Backup*	BB = Battery Backup, if applicable

*Battery Backup is optional

Nomenclature Example: MVE 1536P-190AF-GB-BB. This model has the capacity to store approximately 36,400 vials, Pie-shaped turn-tray dividers, provides a -190°C (+/- 5°C) temperature rating when fully loaded with racks, equipped with a CryoVerse™ Connect controller, Full Auto with the Gas Bypass, and a Battery Backup assembly.

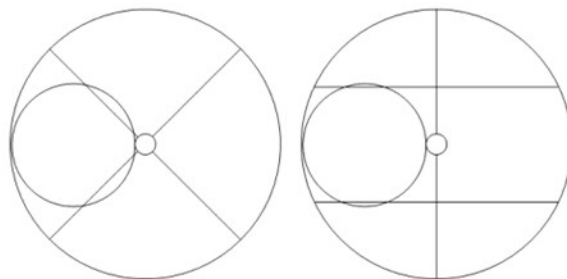
**Figure 71. MVE HE Freezers & top view showing offset neck and P and R turn-trays****18.3 MVE HE Freezer Specifications****Table 6. MVE HE 800 Series Freezer Specifications**

	MVE 800C	MVE 815P	MVE 819P	MVE 816P-2T
Outer Diameter – in (mm) (Door Width Requirement)	32 (813)	32 (813)	32 (813)	32 (813)
Overall, Height - in (mm)	44.6 (1132)	58.2 (1478)	65 (1651)	58 (1473)
Usable Height – in (mm)	13 (330)	26.5 (673)	34.5 (877)	13 (330)
Minimum Ceiling Height – in (mm)	60 (1524)	75.4 (1915)	90.1 (2289)	75.4 (1915)
Step height – in (mm)	N/A	7.9 (201)	7.9 (201)	7.9 (201)
Lift-over height – in (mm)	34.8 (884)	41 (1038)	47.5 (1209)	41 (1038)
LN2 Capacity Vapor Storage (L)	~28	~53	~62	~56
Turn-Tray Platform Height in. (cm)	~7 (17.8)	~7 (17.8)	~7 (17.8)	~7 (17.8)
Qty of Casters	4	4	4	4
Direct Load/Caster (Full) lbs. (kg)	174 (79)	287 (130)	335 (152)	289 (131)
Weight Empty – lb. (kg)	330 (145)	480 (218)	515 (234)	475 (215)
Weight Vapor – lb. (kg)	440 (195)	575 (261)	660 (300)	575 (261)
Weight Full – lb. (kg)	695 (310)	1160 (526)	1340(608)	1155 (524)

Note: All dimensions, capacities, and specifications are estimated and for reference only.

**Table 7. MVE HE 1500 Series Freezer Specifications**

	MVE 1536P	MVE 1539P	MVE 1539R	MVE 1542R
Outer Diameter – in (mm) (Door Width Requirement)	42 (1067)	42 (1067)	42 (1067)	42 (1067)
Overall, Height - in (mm)	55.6 (1412)	58 (1472)	55.6 (1412)	58 (1472)
Usable Height – in (mm)	28.7 (730)	30.7 (781)	28.7 (730)	30.7 (781)
Minimum Ceiling Height – in (mm)	83.2 (2115)	87.8 (2230)	83.2 (2115)	87.8 (2230)
Step height – in (mm)	7.5 (192)	7.8 (198)	7.5 (192)	7.8 (198)
Lift-over height – in (mm)	37.7 (958)	39.5 (1003)	37.7 (958)	39.5 (1003)
LN2 Capacity Vapor Storage (L)	~133	~133	~133	~133
Turn-Tray Platform Height in. (cm)	~9.5 (24)	~9.5 (24)	~9.5 (24)	~9.5 (24)
Qty of Casters	4	4	4	4
Direct Load/Caster (Full) lbs. (kg)	509 (231)	535 (243)	509 (231)	535 (243)
Weight Empty – lb. (kg)	690 (313)	720 (327)	690 (313)	720 (327)
Weight Vapor – lb. (kg)	1728 (785)	957 (435)	1728 (785)	957 (435)
Weight Full – lb. (kg)	2037 (924)	2140 (971)	2037 (924)	2140 (971)

Note: All dimensions, capacities, and specifications are estimated and for reference only.

Table 8. MVE HE 1800 Series Freezer Specifications

	MVE 1842P	MVE 1879P	MVE 1881R	MVE 1892P	MVE 1894R
Outer Diameter – in (mm) (Door Width Requirement)	60 (1524)	60 (1524)	60 (1524)	60 (1524)	60 (1524)
Overall, Height - in (mm)	51.1 (1296)	63.8 (1621)	63.8 (1621)	66.9 (1749)	66.9 (1749)
Usable Height – in (mm)	13.0 (330)	29.5 (749)	29.5 (749)	34 (868)	34 (868)
Minimum Ceiling Height – in (mm)	75 (2130)	90.3 (2294)	90.3 (2294)	98.6 (2504)	98.6 (2504)
Step height – in (mm)	N/A	11.3 (286)	11.3 (286)	11.3 (286)	11.3 (286)
Lift-over height – in (mm)	22.6 (574)	39.1 (1992)	39.1 (1992)	44.1 (1121)	44.1 (1121)
LN2 Capacity Vapor Storage (L)	~290	~290	~290	~300	~300
Turn-Tray Platform Height in. (cm)	~9.5 (24)	~9.5 (24)	~9.5 (24)	~9.5 (24)	~9.5 (24)
Qty of Casters	4	4	4	4	4
Direct Load/Caster (Full) lbs. (kg)	680 (310)	1146 (520)	1146 (520)	1219 (553)	1219 (553)
Weight Empty – lb. (kg)	1157 (530)	1721 (781)	1721 (781)	1721 (781)	1721 (781)
Weight Vapor – lb. (kg)	1673 (761)	2237 (1017)	2237 (1017)	2255 (1025)	2255 (1025)
Weight Full – lb. (kg)	2721 (1237)	4830 (2191)	4830 (2191)	4875 (2211)	4875 (2211)

Note: All dimensions, capacities, and specifications are estimated and for reference only.



19 MVE CryoVerse™ Connect Controller Product Information

The MVE CryoVerse™ Connect Controller is designed to automatically maintain the freezer LN2 level and monitor the temperature of the storage chamber to store biological samples in a cryogenic stasis state. The Controller incorporates advanced features, such as a smart touchscreen color display, freezer temperature and liquid level graphs, the ability to add Journal Entries, user friendly event log, and control of the freezer internal temperature with a high level of precision.

19.1 MVE CryoVerse™ Display System Descriptions

The image below shows the MVE CryoVerse™ Connect normal operating Home screen with the control keypad.

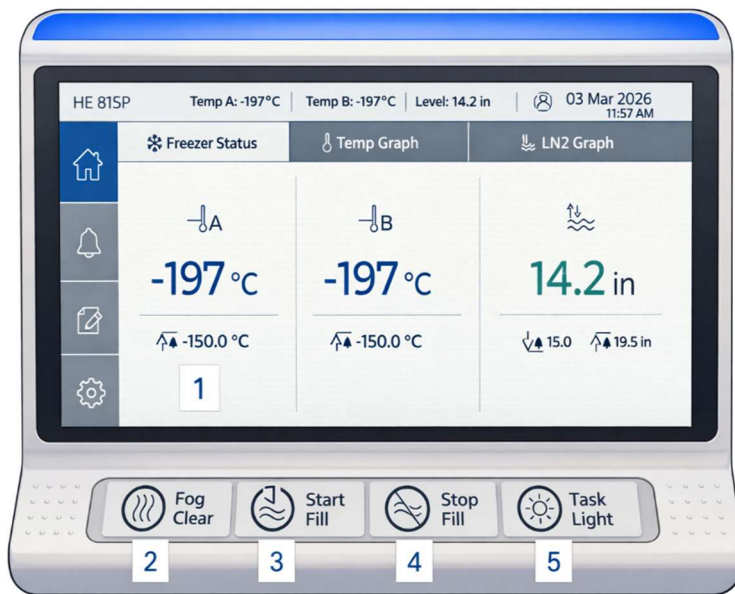

Figure 72. MVE CryoVerse™ Connect Controller & Keypad

Table 9. Controller Keypad

1	*LCD Display	11-inch Touch Screen
2	*Fog Clear	Press and hold to manually perform a Fog Clear
3	START FILL	Used to manually initiate a fill
4	*STOP FILL	Used to manually terminate a fill – Disables Auto Fill for 30 minutes
5	*Task Light	Provides visibility to the workspace area.

*Can be accessed without logging in after exiting the Initial Start Up Screen



19.2 CryoVerse Connect Electrical and Level Connections

The CryoVerse™ Connect's level, electrical input and electrical output connections are located on the underside of the controller.



Figure 73. CryoVerse Connect Electrical & Level I/O

Table 10. CryoVerse Connect Connections

1	36 VDC, 1.8A Controller Input	Main power supply connection
2	Serial Port	RJ-45 connections for Serial/COM 1, daisy-chained
3	USB-A Ports (Qty 2)	Used to download data and load/upgrade firmware
4	LN2 Level Port	Connects the Clear Vinyl Tube to the purge circuit
5	Temp A Port	Connection for Temp A probe
6	Temp B Port	Connection for Temp B probe
7	Freezer Wire Harness Connector (DB-25F)	25-pin wire harness connection to plumbing assembly, turn sense, lid sensor, lid lock, inlet temp sensor and backup battery
8	Discrete Alarm Outputs	Open collector alarm terminals
9	Global Alarm Relay	Dry contact alarm terminals (normally open, normally closed)

19.3 CryoVerse Connect 25-Pin Female Freezer Wiring Harness Connections



**Table 11. 25-Pin Connections**

PINOUT	WIRE AWG	COLOR	LENGTH (IN)	DESCRIPTION
1	20	BRN/WHT	54	PURGE VALVE-
14	20	BRN	54	PURGE VALVE+
2	20	GRY/WHT	54	FILL VALVE-
15	20	GRY	54	FILL VALVE+
3	20	ORG/WHT	54	BYPASS VALVE-
16	20	ORG	54	BYPASS VALVE+
22	22	RED	54	INLET TEMP+
23	22	RED/WHT	54	INLET TEMP-
4	22	BLU/WHT	60	LID UNLOCK-
17	22	BLU	60	LID UNLOCK+
6	22	YEL	56	+5VDC
8	22	GRN	56	GND
10	20	BLK/WHT	12	BATTERY BACKUP-
11	20	BLK/WHT	12	BATTERY BACKUP-
12	20	BLK	12	BATTERY BACKUP+
13	20	BLK	12	BATTERY BACKUP+



20 MVE CryoVerse™ Connect Controller Specifications

Table 12. Specifications

Control System	Specification
CryoVerse™ Connect Controller Dimensions Length Width Height Weight	4.5 in. (11.4cm) 10.5 in. (26.7 cm) 11.0 in. (28 cm) 7.5 lbs. (3.4 kg)
Controller Power Requirements Wireless USB-A Port (Qty 2) Global/Discrete Contacts	36VDC 1.8A 5GHz 802.11 USB 2.0, 0.5A-Single Device 0.25A-Two Devices Dry Alarm Contacts, NO/NC
Power Supply Brand Input/Connector Output Input Current (continuous) Input Power (max)	Globtek PR9SY1800KPPX4-IMR6B 100-240VAC 50-60Hz 4-pin Locking 36VDC 1.8A 1.8 Amps 65 Watts
Temperature Sensors Type Connectors Quantity Resistance Sensitivity Resolution Accuracy – Single Point Calibration * – Two Point calibration ** Range * Accuracy determined over range of -200°C to - 135°C. ** Accuracy determined over a range of -200°C to 0°C.	M12-A RTD Temperature Probe Threaded Circular secure connectors 2 PT-1000 RTD -200°C to 70C ± 1.0°C 0.1°C (0.2°F) ± 2.0°C (3.6°F) ± 1.0°C (1.8°F) - 200°C to 70°C (- 328°C to 158°F)
Level Sensor Type Accuracy Resolution Range	Differential Pressure ± 0.5 in (1.3 cm) ± 0.5 in. (1.3 cm) LN2 0.1 in. (0.3 cm) 3.0 in. to 41.3 in. (7.6 cm to 105 cm)
Oscillating LED Lamps	Steady, Alarm, Rotating
Battery Backup	2 x 12VDC 9AH Sealed Lead Acid (Running on BB Approx. 24hrs with one 30 min Fill cycle)



21 MVE Plumbing System

The MVE HE plumbing assembly safely and efficiently carries and regulates the flow of LN2 from the liquid supply through the annular fill line and into the freezer. It transmits the LN2 differential pressure level signal to the controller. Each configuration is comprised of three main circuits: a fill circuit, a purge circuit, and a gas bypass circuit.

21.1 MVE HE Plumbing Components

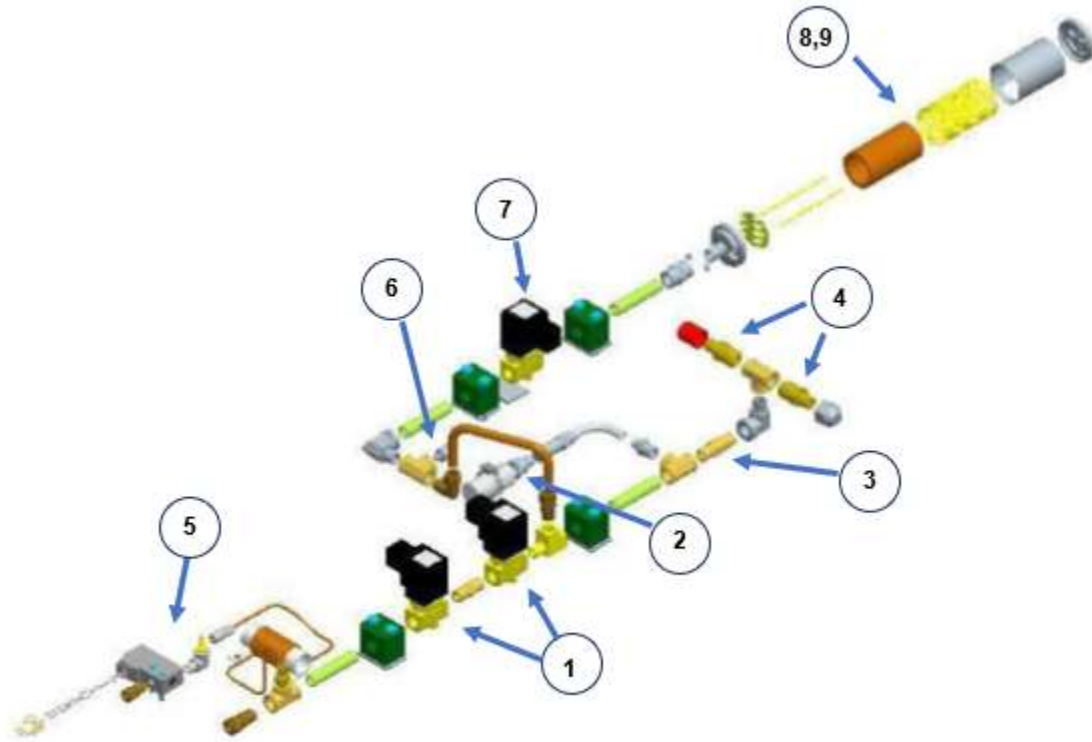

Figure 74. MVE HE Plumbing Overview

Table 13. MVE HE Plumbing Component Part Numbers

Key	Part Number	Component	Spec Details
1	21040465	Fill Solenoid Valve	24 VDC, R ≈ 60 - 80 Ω (single), 30 - 40 Ω (dual)
2	1810032	Pressure Relief Valve	50 PSI (3.45 bar)
3	11648945	Inline Filter	40-micron
4	1110052	Fill Transfer Hose Connections	½ in. ODT, 45° flare, ¼ in. MPT
5	13284954S	Purge Valve (3-way)	24 VDC, R ≈ 130 - 145 Ω
6	10713400	Gas Bypass Temp Sensor	Pt-1000 RTD
7	21040465	Gas Bypass Solenoid Valve	24 VDC, R ≈ 60 - 80 Ω
8	11499812	Gas Bypass Muffler	-
9	11885449	Gas Bypass Muffler Deflector	-



22 Operating Environment

22.1 Ambient Temperature and Relative Humidity

MVE cryogenic freezers are designed to be operated in environments near room temperature (50°F – 95°F, 10°C – 35°C) and relative humidity below 50%. Due to the large gradient between LN2 and ambient temperatures, an additional change of a few degrees will not have a significant impact on the freezer performance. The relative humidity should be maintained between 5 and 95% RH, non-condensing so that condensation does not form on the CryoVerse™ Connect Controller. Elevated humidity levels can lead to excessive condensation and frost on and around the lid. In situations where the relative humidity is high and uncontrollable, the lid should be routinely wiped dry to prevent ice formation. Should significant ice formation develop, thaw as necessary. Refer to the Preventive Maintenance procedures for details.

Atmospheric Pressure

MVE cryogenic freezers are designed to be operated in environments with atmospheric pressure range of 66.3 kPa (3,500 meters) to 102 kPa (-50 meters).

Thermal Load

Since MVE Freezers use LN2 as the refrigerant and do not employ any type of mechanical refrigeration, the thermal load will be negligible to negative. Vaporization of LN2 within MVE Freezers provides stable cryogenic temperatures.

Vibrations & Noise

MVE Freezers do not generate vibrations or environmental vibration hazards. Flow noise is generated by the pressurized LN2 supply when system relief valves release excess pressure. There is minimal noise generated from MVE Freezers as they purge and fill.

Decontamination and Disposal

MVE freezers are designed for the safe and efficient storage of biological samples at cryogenic temperatures. The freezer must be properly decontaminated prior to freezer shipment or disposal. Contact Technical services for more information. The battery backup cells are sealed lead acid batteries. These and other electrical components should be properly recycled or disposed of according to local regulatory guidelines. The freezer itself is a stainless steel, vacuum insulated vessel with an aluminum turn tray. Once the freezer has been decontaminated and any prohibited components are removed, the freezer may be disposed of or recycled according to local regulations.



23 Infrastructure Requirements

Table 14. Infrastructure Requirements

Electrical	100 – 240VAC 50-60Hz 0.6A continuous, 1.5A full load
LN2 Supply	22-35 PSI (1.5-2.4 Bar) CGA-295
Ventilation	Normal room air change rate minimums are typically sufficient for LN2 freezers. Verify your Health and Human Safety Officer or equivalent group.
Oxygen Monitoring	MVE recommends Oxygen Monitoring and Alarm systems for any LN2 installations.
Seismic Restraint	For earthquake prone areas seismic restraints may be required. Check your local standards and regulations.



24 Installation (Uncrating)

24.1 Items Included with MVE Freezers

The reusable crate should be un-crated following the procedures below. Always inspect the bill of lading for accuracy and external crate/packaging for damage before accepting the shipment.

Included with each MVE Freezer:

- Quick Reference User Manual – <https://mvebio.com/resources>
- Manual Freezer Status Log
- CryoVerse™ Connect Controller – Packaged in a box separately
- Transfer hose – 6 ft. – Packaged Inside freezer
- MVE Dipstick – Packaged Inside freezer
- Desiccant bag – To be removed and discarded – Inside freezer
- Liquid Nitrogen handling instructions
- MVE Certificate of Quality



Figure 75. Crated & Uncrated Freezer

24.2 Uncrate Freezer

To uncrate, first unscrew the top, then all the sides, use a prybar for materials that are stapled, and save all wood materials. The MVE 1500 and 1800 Series use a heavy-duty skid/pallet that is equipped with extra 2x4 inch supports at the front and rear. Carefully remove these. The MVE 800 Series can be moved from the skid/pallet using one of the walls from the crate as a ramp.

To remove freezer from the pallet, using a forklift with extended forks, slowly slide the forks underneath from the rear of the freezer, slowly and making sure to clear the casters, as shown in Figure 76 below.

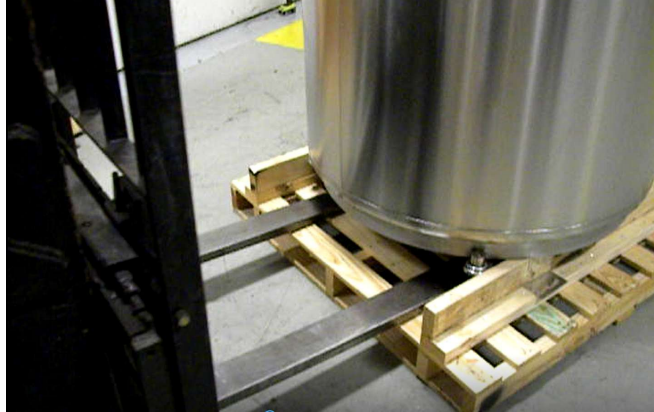

Figure 76. Example Forklift Removal of Freezer from Pallet

As shown in Figure 77, slowly lift the freezer, and instead of moving the freezer, raise it just enough to slide away the pallet and then lower the freezer. Using one or both handles on the side of the freezer, move the freezer on its casters to the room or area for setup.



Figure 77. Removal of Pallet from Underneath Freezer

25 Installation and Freezer Setup

25.1 Setting up MVE Freezer

Installation



NOTE: Verify A/C power source is 100-240VAC and is properly grounded. Do not apply power to the CryoVerse™ Connect Controller or connect an LN2 supply until later in this procedure to avoid injury or damage to the equipment.



Following the careful uncrating and unpacking of the freezer, install using these basic instructions. The MVE HE Series freezers will be shipped with most connections described below factory installed and connected.



NOTE: Only install the freezer on a level surface. Never fill freezer and move to another location. Always fill the freezer where it is to be installed/used.



NOTE: The freezer should be installed in an area appropriate for LN2 service with adequate ventilation, and the room should be equipped with an oxygen monitoring system.



NOTE: Do not position the freezer in an orientation that makes it difficult to remove the power supply from main power. Recommend spacing MVE freezers at a minimum of 6 inches or more.

1. Verify A/C power source is 100-240VAC and is properly grounded. Do not connect the power source until later in the installation.
2. Locate the temperature sensor tube assembly that will house the two MVE temperature probes.
3. The MVE HE Series freezers are equipped with a three-tube temperature sensor assembly that are factory installed in the center of the top of the freezer. The two smaller tubes are designed to house the included MVE temperature sensors. The third larger tube is designed to accommodate a third-party temperature sensor. A silicone plug will be installed in this third tube. If the third tube is going to be used, simply remove the silicone plug. If not, please use silicone to seal this hole.

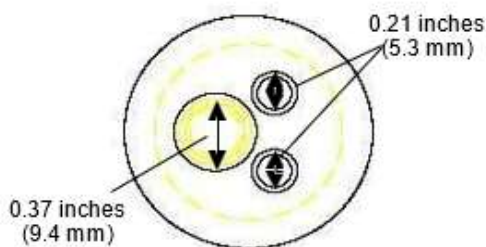

Figure 78. Temperature 3-Sensor Tube

4. Insert the two temperature sensors into the sensor tubes and position the sensors at the preferred height within the freezer storage chamber. The brass nut should be hand tightened. Selecting sensors, A and B as well as sensor placement is adjustable within the freezer. Check with the end user. MVE recommends placing



temperature sensor (Temp A) at the “top box” level. This refers to the level in the freezer space where the highest sample is being stored. If storing vials in boxes, then this would be at the level within the top box.

5. Verify, connect the temperature sensors to the CryoVerse™ Connect temperature ports (5 and 6 in Figure 79) using the Threaded Circular connectors.



Figure 79. Temperature Sensor, Liquid Level, Freezer Harness and DC Power Connections

6. Once the temperature sensors are in their desired position, apply a small amount of silicone sealant, included with the freezer, surrounding the temperature sensors where they enter the sensor tubes. This will help maintain their position and prevent moisture ingress from entering the freezer storage chamber.
7. Connect the clear vinyl tube to the CryoVerse™ Connect controller Level Input hose barb fitting (4 in Figure 79) and connect the other end of the tube to the 3-way purge valve.

Verify the plumbing assembly cable connections from the controller are secured and the backup battery (if equipped) is not connected. Connect the 25-pin freezer wire harness to the CryoVerse™ Connect controller (7 in Figure 79).

8. Ensure AC power is OFF, then connect the DC power cable DIN connector to the CryoVerse Connect (1 in Figure 79).



9. Connect the power supply to an appropriate wall outlet with the proper AC voltage. Avoid wall outlets that are connected to emergency generator power, if possible, as this power source may be inconsistent and may cause voltage fluctuation. False power failure alarms or falsely trigger global and discrete contacts may be possible. Although an uninterruptible power supply (UPS) is ideal to ensure continuous power, a surge protector or a power conditioner is recommended.



NOTE: Only use the MVE factory provided power supply

To avoid the risk of electrical shock, this equipment must only be connected to a properly grounded power source or outlet.

10. Connect the two-pin battery backup connector to the main wire harness.
11. Connect the AC power cord to the power entry module located at the rear of the freezer and to the right of the plumbing shroud, as shown in Figure 80. AC power to the freezer can be disconnected using the switch on the power entry module or by removing the power cord from the power entry module receptacle. The power entry module also contains a replaceable fuse (5x20mm, 250V, 4A) located between the receptacle and the switch.



Figure 80: AC Power Cord Connection to Freezer Power Entry Module

Turn on AC power using the power switch shown in Figure 80.

26 CryoVerse™ Connect Initial Pre-Setup (Quick Start & Initial Fill)

26.1 CryoVerse™ Connect Controller Pre-Setup Screen (Quick Start)

The CryoVerse™ Connect controller incorporates an easy-to-use setup routine that helps avoid nuisance alarms as the freezer reaches equilibrium (cools down).

1. Connect the 4-Pin power supply to the CryoVerse™ Connect Controller (1 in Figure 81) being careful to align the connector notch with the DIN plug. The Setup screen will appear. **There will be no audible or visual alarms activated during the initial setup.**



Figure 81: DC Power Supply Connection

2. As the CryoVerse™ Connect controller powers up the display will illuminate and the startup sequence will commence as indicated by the MVE logo and a series of audible beeps. Once startup is complete, either the Initial Setup or Home Screens will display.



Figure 82: MVE Startup Window



3. Touch the “Set Admin Password”. A pop-up keyboard will appear; enter a ****New password**. The password requirement is any 8 characters, alpha or numeric, upper or lower case. After the password is entered, simply touch “Finish Setup” or you can set Time Zone, Language, Temp A and B High alarms, Liquid Level alarms and setpoints. Setpoints can also be adjusted later. Once Finish Setup is pressed this screen does not appear when restarting.

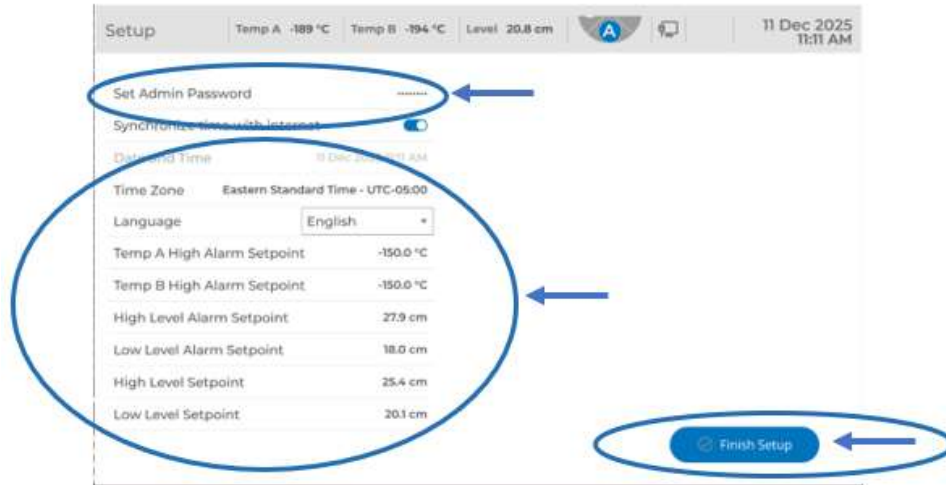

Figure 83. Initial Setup Screen

4. After pressing Finish Setup the alarm will sound immediately if Temp A&B and Low Level alarm thresholds are not met, Slide to silence the alarm. We recommend logging in as this will record in the event log who has muted the alarm (helpful when troubleshooting). The alarm will be silent for 30 mins. The CryoVerse™ Connect Controller is **not equipped to disable the audible alarm**, only silence the alarm for 30 min.



Figure 84: Slide to Silence Alarm



- By default, you are the “Admin”. Press the Log in icon and enter your newly created password. ****Important, save the password in a secure location.****

“Fog Clear”, “Fill Stop”, “Task Light” buttons and the “Home”, “Alarms” and “Journal” pages can be accessed without logging in.

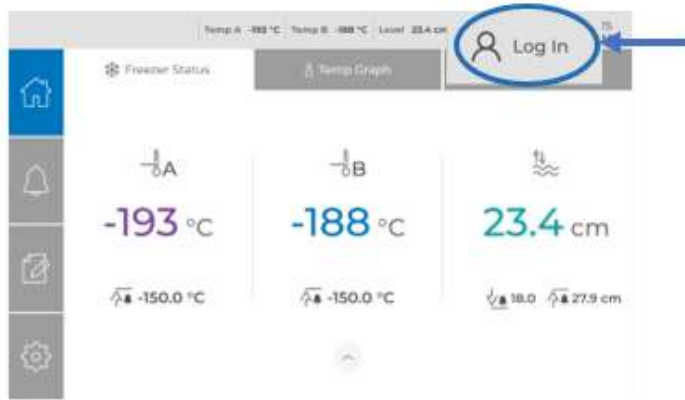

Figure 85: Log in Icon

Once logged in, additional Admins, Distributors & Users can be added. **Refer to “Log in and setting up Usernames and Passwords” section of this manual.**

If the controller is restarted, simply Log in with the username “Admin” and the ****New password** you’ve created. Forgetting the password will delay the quick start procedure.

If the password is forgotten and if you are still logged in as admin or distributor, press **“Factory Reset”**, as this will bring you back to the Setup screen. Reenter a new password.

If you are logged out and have forgotten the password, contact the admin of the CryoVerse™ Connect controller or your distributor to reset your password, or contact MVE Technical Service (1-844-MVE-CRYO) and follow their instructions to reset the password.

- Once logged in touch the Home screen icon



Figure 86. Home Screen Settings Location



7. On the Home screen, below Temp A, Temp B, and LN2 Level are “Quick Access Hot Keys”, to change setpoints. Touch to change setpoints. **Must be logged in.**



Figure 87. Home Screen Hot Keys Location

The CryoVerse™ Connect controller has a new feature to Clone controllers (**Refer to the *Advanced Settings section of this manual***). This feature allows copying controller settings and transferring those settings to another CryoVerse™ Connect controller.

The default language is set to English. The freezer can also be named. These settings can be changed, updated in the “General Settings”, section of this manual.



26.2 Start Initial Fill Cycle

Verify LN2 supply source pressure, 22-35 psi (1.5 – 2.4 bar).

Ensure the CryoVerse Connect controller is on and log in.

1. Inspect and verify LN2 Supply source pressure, connect provided LN2 transfer hose, check for leaks
2. Inspect and open/remove lid, remove internal packaging components and desiccant packs
3. Load empty inventory system
4. Turn on the CryoVerse Connect Controller
5. Login in as an admin or distributor
6. Press “Start Fill” to commence the fill cycle routine.
7. When the fill cycle completes, wipe down any frost or condensation to keep the neck dry, then install/close the lid.



Once the fill cycle completes the CryoVerse™ Connect controller will continue to maintain LN2 levels while monitoring and logging storage conditions. Allow the freezer to cool down for approx. 48 hours. Only after the top box temperature has stabilized can samples then be introduced. Make sure to routinely verify freezer LN2 level and ensure there is sufficient LN2 supply volume and pressure.

Note: The CryoVerse™ Connect Controller has a built in restricted idle feature that is set for 30 minutes. Pressing Stop Fill will disable the auto-fill function for 30 minutes. Manual fills can be started at anytime. Also, when logged in as admin, you can enable or disable “Allow Manual Fill without logging in” in the Liquid Level settings. Enabling this feature will allow anyone to initial a manual fill by pressing the “Start Fill” button.



26.3 Alarm Conditions During the Initial Fill Cycle

Alarm behavior is modified during an Initial Fill Cycle (New Freezer First Fill) as described below:

1. When doing an initial fill mode, (First fill or filling an empty tank) with a new controller, manually pressing the Start Fill button will:
 - A. Ignore the alarms for Temp A and Temp B, Low Liquid Level, Pressure Loss, Fill Time, and Stuck Valve.
 - B. Pressing Stop Fill before the low level setpoint is reached keeps the freezer in initial fill mode
 - C. When the level is above the low level setpoint, the controller will automatically enable alarms for Temp A and Temp B, Low Liquid Level, and Pressure Loss.
 - D. As it continues to fill to its high level setpoint, the Fill Time and Stuck Valve alarms will still be ignored.
 - E. Once the freezer reaches its high level setpoint the controller will stop the fill and automatically enable the Fill Time and Stuck Valve alarms.
 - F. The initial fill mode will happen only once and will not recur.
 - G. After initial fill is complete, the controller will perform normal auto-fill cycles with all alarms activated. Fill cycles are initiated by manually pressing the Start Fill button, an Auto Fill if the liquid level drops below the low level setpoint and auto fill is enabled or a Scheduled Fill if enabled.
2. Disconnecting the controller (headless mode) will not stop initial fill mode.
3. If installing a new controller on a tank that has liquid, and you manually press the “Start Fill” button, if the fill level is below the low-level set point it will enter the initial fill mode state; otherwise, it will enter the normal manual fill state.
4. When it is in initial fill mode the display will appear normally, showing it is filling.



27 MVE Freezer Theory of Operations

27.1 Temperature Measurement (Theory)

The CryoVerse™ Connect is equipped with two independent temperature measurement channels. They are designed to be used with two M12-A 1000-ohm platinum RTD probes. The electrical resistance of the very fine platinum wire in these probes changes linearly with temperature. Platinum's linear relationship between resistance and temperature makes PT-1000 RTDs ideal for temperature measurement in cryogenic environments. The temperatures displayed on the display are not real-time readings, but rather a running average of the previous few measurements. The controller takes temperature measurements several times a second and averages them while updating the displayed temperature every second. The Inlet/hot gas bypass temperature sensor is also a 1000-ohm platinum RTD.

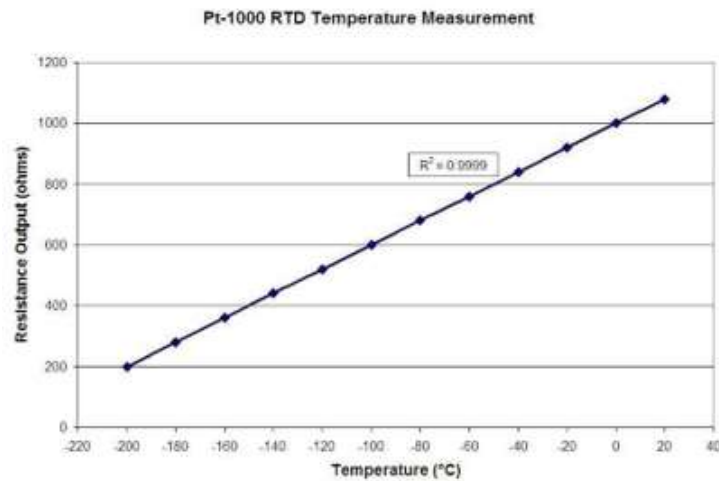

Platinum's linear relationship between temperature and resistance

Figure 88. Temperature Sensor Platinum's Linear Relationship



27.2 Automatic Liquid Nitrogen Level Measurement (Theory)

The LN2 level in the Dewar is determined using a differential pressure sensor. This sensor operates on the physical principle of hydrostatic head pressure. The pressure generated by a column of fluid is proportional to the height, or depth, of the fluid column. In this application, the pressure generated by the LN2 at the bottom of the freezer will increase as the LN2 level increases. This differential pressure system allows the controller to measure the LN2 level accurately.



As the fluid level in the cylinder increases, the imposed head pressure at the bottom of the cylinder increases proportionally. The pressure gauges measure this increase in level.

This pressure signal generated by the LN2 is transmitted from the bottom of the inner vessel through the freezer's annular line to the differential pressure sensor in the CryoVerse™ Connect controller. The differential pressure column is connected via the clear vinyl tube from the plumbing system to the controller's level input connection. The CryoVerse™ Connect then compares this pressure signal to its atmospheric pressure readings and is then able to determine the exact LN2 level. The term "differential pressure" refers to the fact that the level is determined from the difference between the hydrostatic head pressure of the fluid column and atmospheric pressure. The measured LN2 level is displayed in inches or centimeters.

Unlike alternative level sensing systems, such as thermistor-based systems, differential pressure allows the exact level to be measured and displayed, not just a level range. This completely enclosed system requires minimal maintenance. Also, the differential pressure system allows the automatic level settings and alarms to be set and adjusted electronically instead of having to physically move sensors.

The CryoVerse™ Connect is equipped with a fully automated LN2 level control system. This level control system is based on user-defined parameters. The controller can monitor level within ranges of 3.0 in. to 41.3 in. (7.6 cm to 105 cm). The controller will not allow a liquid Low-Level setpoint of 3 inches (7.5 cm). We also do not recommend setting the Low-Level alarm to 3 inches (7.5 cm).



Since this control system utilizes the differential pressure system described previously, these parameters can be adjusted electronically using the CryoVerse™ Connect touch screen. The automatic fill control feature can be disabled via the Settings menus.

Below is a brief explanation of the four user- defined level control parameters.

High Level Alarm – If the LN2 level in a freezer reaches or exceeds this setting, a High-Level Alarm will result. This audible/visual alarm will cause the High-Level discrete contact and the global remote to switch to alarm state.

- **High Level Setpoint** – When the LN2 level in a freezer reaches this setting (with or without automatic fill enabled) the controller will close the fill valves and terminate the fill.
- **Low Level Setpoint** – When the LN2 level is at or below this setting (with automatic fill enabled) the controller will initiate a filling cycle.
- **Low Level Alarm** – If the LN2 level in a freezer is at or below this setting, a Low-Level Alarm will result. This audible/visual alarm will cause the Low-Level discrete contact and the global remote to switch to alarm state.

NOTE: Certain events can temporarily disable Auto Fill Control. Pressing “Stop Fill” will disable Auto Fill Control for 10 minutes. The CryoVerse™ Connect has a restricted idle feature that is set for 10 minutes. In the event of a Hot Gas Bypass Alarm or a Fill Time Alarm, Auto Fill Control will be disabled until the respective alarm is “Silenced” or restarting the controller. The overfill protection will prevent an automatic fill if the LN2 level reading is at zero “0” or if the level reading suddenly drops to zero “0”. This prevents an overfill scenario in any situation where the CryoVerse™ Connect loses its ability to measure the LN2 level.

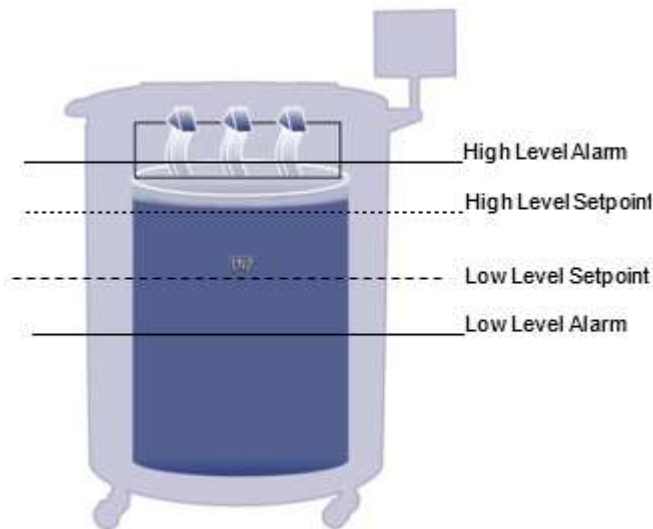

Figure 89. Example of automatic level control parameters



27.3 LN2 Volume Per Inch (Theory)

The below values are only estimates and should not be used to compare controller's usage value. These values also do not consider inventory components that will displace LN2. Do not refer to the LN2 Volume per Inch to measure a freezer's LN2 efficiency, its evaporation rate, or to compare what the controller displays as a usage value. These values are meant to only help understand volume of Liters needed for first fills.

Table 15. LN2 Volume Per Inch (Theory)

Freezer Model	Inches	Liters
MVE 800 Series	1	10.1
MVE 1500 Series	1	19.3
MVE 1800 Series	1	40.8

All MVE Freezers utilize LN2 as the means of refrigeration. Under atmospheric conditions, the temperature of LN2 is -196°C (-320°F, 77 K). Depending on the model, the LN2 resides either in or below the freezer storage space. Through normal usage and time, the LN2 will naturally boil off reducing the amount of refrigerant in the freezer. It is imperative that the LN2 level be properly maintained for the storage space temperature to be maintained. This, along with monitoring and recording temperature, is the main function of the CryoVerse™ Connect Controller.

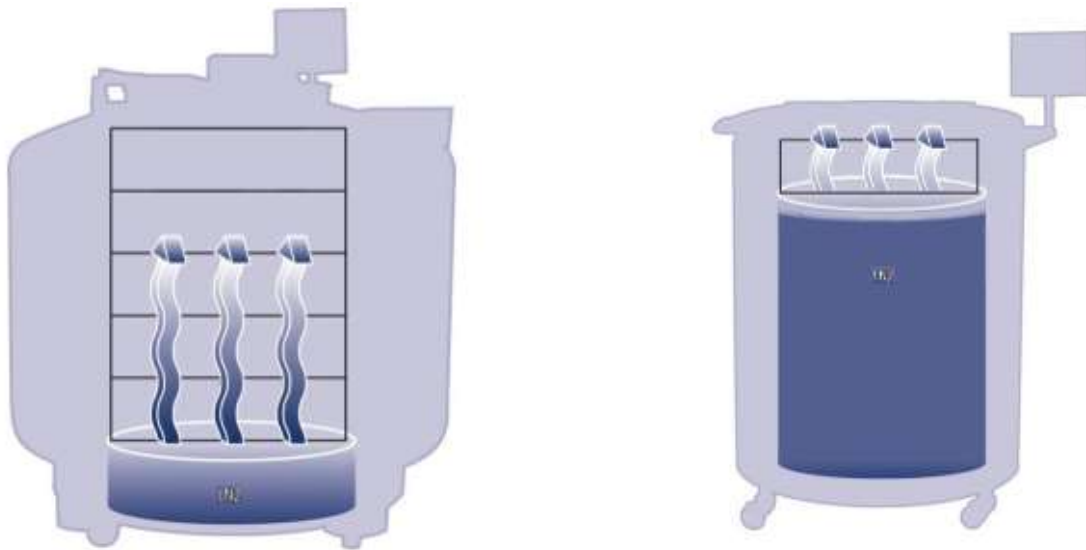

Left: LN2 below the storage space naturally boils off and cools the freezer. Right: LN2 resides in the freezer storage space.

Figure 90. Illustration showing LN2 as the refrigerant.



27.4 MVE CryoVerse™ Connect Functions and Features

The CryoVerse™ Connect utilizes a variety of functions and features that enables it to closely monitor and control the environment inside a cryogenic freezer. Listed below are its features and their functionality:

- Liquid Nitrogen Level Measurement
- Automatic Liquid Nitrogen Level Control
- Temperature Measurement
- Alarms & Descriptions (Reference Alarms Descriptions section)
- Usernames & Passwords (Reference Usernames section)
- Lid Open Alarm and Fog Clear capabilities (Reference Lid Switch Settings)
- Inlet/Bypass (Reference Inlet/Bypass Settings)
- Battery Backup (Reference Battery backup Settings)
- Communication Capabilities, Wi-Fi, Email Communications



28 Preventive Maintenance

This section describes and preventive maintenance that should be performed on MVE freezers to ensure optimum operation and performance, as well as maximize service life. As with any technical piece of laboratory equipment, preventive maintenance is key to equipment success.

28.1 Periodic Preventive Maintenance Schedule

This is the MVE recommended preventive maintenance schedule. MVE Distributors may have a more comprehensive maintenance/service plan.

Table 16. Periodic Preventive Maintenance Schedule

	Weekly	Monthly	6 Months	12 Months	24 Months	60 Months
Level Verification	●					
Verify Adequate Supply	●					
Plumbing Leak Check		●				
Level Alarm Test			●			
Thaw Freezer Lid, & Lid Switch inspection			●			
Lid Hinge Inspection			●			
Folding Step Inspection			●			
Inline Filter Replacement				●		
Solenoid Valve Replacement (Fill, Bypass, Purge)					●	
Relief Valve Replacement					●	
Lid gasket Inspection and/or replacement					●	
Backup Battery Replacement						●

28.2 Freezer Maintenance

Check freezer at a five-year interval and thaw only if ice builds up enough to impede the proper insertion, access and retrieval of inventory system. Also, if ice affects the accuracy of the liquid level reading complete Freezer Thaw and Moisture Removal may be necessary. See the procedure below.

1. Remove freezer's LN2 supply.
8. Disable or disconnect the CryoVerse™ Connect Controller's battery backup and disconnect the A/C power.
9. Open or remove the lid from freezer.
10. Allow LN2 to completely evaporate and the freezer space to warm to room temperature. Placing a fan blowing into the freezer will accelerate this process.
11. After it has reached ambient temperature thoroughly remove any moisture from the freezer space. This can be done with a wet/dry vacuum and towels. For High Efficiency models, open the hinged hatch access panel on the bottom of the turn-tray to access the bottom of the freezer.



12. Once moisture has been removed from the freezer space, purge the plumbing assembly and annular lines with nitrogen gas. Compressed nitrogen or the gas use valve on a LN2 cylinder work best. The LN2 cylinder vent valve can also work but will deplete the cylinder head pressure quickly. Ensure the nitrogen gas pressure does not exceed 50 PSI (3.4 bar).
13. Plug in the the CryoVerse™ Connect Controller's main power and connect the freezer plumbing via transfer hose to a compressed nitrogen supply or the gas use valve on a LN2 cylinder. Ensure gas bypass is disabled if equipped.
14. Press "Start Fill" and allow the freezer to fill for 30 seconds.
15. Press "Stop Fill"
16. Press "Start Fill" and allow the freezer to fill for 30 seconds.
17. Continue, cycling fills for 30 seconds until the plumbing assembly and annular lines are clear and completely dry.

In some cases, it may be necessary to purge the level sensing annular line separately. This can be done by connecting pressurized nitrogen gas directly to the freezer annular line fitting.



CAUTION: Ensure that the LN2 supply valve is closed and the plumbing assembly is vented before loosening the compression fittings and removing the annular line tube.

1. Loosen and remove the 1/4-inch compression fittings from the purge valve and the freezer annular line fitting.
18. Remove 1/4-inch copper tube and purge to clear any moisture.
19. Connect nitrogen gas source directly to the freezer's 3/8-inch FPT annular line connection.
20. Purge the annular line with nitrogen gas, maintaining a pressure below 50 PSI (3.4 bar), until the line is clear and completely free of any moisture.

NOTE: If moisture is not completely removed from the freezer space and annular lines, ice will form when LN2 is reintroduced into the freezer. Ice blockage in the freezer space or annular lines will interfere with the proper function of the freezer's level sensing system.

ENSURE ALL MOISTURE IS COMPLETELY REMOVED PRIOR TO INTRODUCING LN2



29 Preventive Maintenance Procedures

This section will provide an overview of performing service and maintenance on MVE cryogenic freezers and components.

29.1 Level Verification

The differential pressure measurement system used on MVE freezers is nearly maintenance free. It provides a high level of accuracy and resolution to give the operator a precise indication of the exact amount of LN₂ always present in the freezer. Despite its reliability, it is important that the accuracy of the level measurement system is verified on a weekly basis. This will prevent a control system-malfunction from adversely affecting the temperature in the freezer storage space. Use the dipstick provided with each MVE freezer to manually measure the amount of LN₂ in the freezer. Follow the “Dip Stick Procedure” listed in Initial Fill section, to properly measure the liquid level. If the level is off by 1.0 inch (2.5 cm) or more, follow the level adjustment procedure listed in the aforementioned section.

29.2 Verify Adequate LN₂ Supply & Pressure

Adequate LN₂ supply pressure and flow is imperative to the proper operation of MVE freezers. Any LN₂ supply whether from bulk tank or liquid cylinder must be able to maintain a pressure of 22-35 psi (1.52 – 2.41 bar) during a filling cycle and must have enough liquid to ensure the completion of a fill cycle. Many nuisance alarms reported from MVE freezers are due to inadequate supply.

1. Observe the pressure of the supply source. Ideally, pressure should be 22 – 35 psi (1.52 – 2.41 bars).
21. NOTE: It is very common for the pressure gauge on an industrial liquid cylinder to be inoperative. If you suspect this to be the case, install a pressure gauge inline between the liquid cylinder and the freezer for verification
22. Verify the amount of liquid in the supply source. Most bulk tanks have some method of digital or analog volume measurement. Liquid cylinders typically use a sight gauge. As with the pressure gauge on liquid cylinders, it is common for the sight gauge to be inoperative.
23. The minimum amount of liquid necessary in the supply should be enough to completely fill the number of freezers it is supplying. This amount can be determined from the LN₂ inch to volume table in the Appendix.
24. Initiate a fill start on at least one freezer on the network. The supply system should be able to maintain appropriate pressure throughout the duration of the fill cycle.
25. If the supply is determined to be inadequate, have your gas supplier replenish/replace the supply.

29.3 Plumbing Leak Check

Leaky plumbing connections can create a host of problems including but not limited to:

- Slow fill times
- Nuisance Alarms
- High LN₂ Consumption



- Inaccurate level readings
- Inaccurate liquid usage readings

Leaky plumbing connections are especially common on liquid cylinder supply systems, since the fittings are regularly loosened and tightened during liquid cylinder swap out.

1. With the supply system at operating pressure, thoroughly spray all transfer hose connections and freezer plumbing connections with leak detect solution
26. Allow leak detect solution to penetrate fittings for at least 30 seconds
27. Large leaks will be immediately apparent with large bubble formations
28. Small leaks will take longer to detect, with small bubble formation in the appearance of “foam”
29. Most leaks can be repaired by tightening the suspect fitting with a crescent or appropriately sized wrench.
30. If tightening the fitting does not fix the leak, check the fitting for cracks and or galling. If the fitting is damaged, replace.
31. Recheck any replaced fittings for leaks.

29.4 Level Alarm Test

The CryoVerse™ Connect Controller can trigger a liquid high level or low-level alarm if the LN2 level in the freezer exceeds the user defined parameters.

High Level Alarm Test:

1. Observe and record the current LN2 level
32. Record the current level settings. This can be accessed on the Home screen Level display or touch Settings and navigate to the Liquid Level menu. The current LN2 level should be between the High-Level Alarm setting and Low-Level Alarm setting. If not, allow the freezer to fill until it reaches its High-Level Fill set point.
33. Record the current Level-offset value. Adjust the level offset so that the current level is a value that is greater than the High-Level Alarm setting. **For example, if the High-Level Alarm setting is currently 10.0 inches (25 cm), increase the offset value by at least 1.0 inch (2.5 cm). This will cause the controller to think that the level inside the freezer is higher than actual.** Reference the section for the level offset adjustment.
34. Observe the audible/visual alarm. Be aware that the level alarms have **a one minute delay**?. This delay is intentional and is to prevent nuisance alarms.
35. Verify the alarm triggers.
36. Decrease the offset value back to the original observed setting.

Low Level Alarm Test:

1. Observe and record the current LN2 level.
37. Remove the vinyl tube by turning it counter-clockwise from the hose barb on the bottom of the CryoVerse™ Connect Controller. Be careful not to damage the tube.
38. The displayed level should drop to 0.0 inches.
39. After one minute?, the audible alarm should sound
40. Reconnect the vinyl tube by turning it clockwise. If the tube is deformed at the end, it may be necessary to trim off ¼” of the tube to ensure a good connection.



41. Press “Fill Start” to purge the level sensing line. After 30 seconds, the level should gradually increase to the original value.
42. After the fill cycle is complete, manually measure the level using the dipstick. Adjust using the Level-offset if necessary.

29.5 Thaw Freezer Lid

Lid Thaw Procedure

1. Open or remove lid from freezer. Depending on the freezer model, it may be necessary to remove the lid from the hinges for it to completely warm to room temperature.
43. It is recommended that the freezer opening be covered with a spare lid or in another non- airtight manner to prevent moisture from entering the storage space and to minimize the top box temperature change while the lid is open.
44. Allow lid to sit at room temperature for approximately 30 minutes.
45. Once thawed, thoroughly dry lid, cork, and liner.
46. Inspect lid for damage and replace parts if necessary.

29.6 Lid Switch & Hinge Inspection

Inspect the lid switch to be sure it is not damaged. Perform a Fog clear test by opening the lid. If the fog clear system activated the lid switch is operational.

Lid Hinge Inspection:

MVE freezers with hinged lids should be inspected for integrity at least every 6 months. Verify that the hinges are free of damage and securely attached to the freezer and lid. MVE hinged freezers are designed for easy opening and closing. Ensure the lid opens smoothly. Ensure lid closes smoothly and comes to rest centered on the freezer. Adjust hinges or replace as needed. For part numbers, contact Customer Technical Service with the freezer serial number.

29.7 Folding Step Inspection

MVE 1500 and 1800 series freezers equipped with folding steps assemblies that should be inspected for integrity at least every 6 months. Verify that hinges are free of cracks and all connections are secure. Check that the anti-slip strips on the steps are in good condition and replace if necessary (PN 4810179). Ensure the step locking strap can securely hold the steps in their folded position. If the pivot bolts continuously loosen, apply thread locker (PN 11087674) and retighten.



30 Service & Parts Replacements

30.1 Inline Filter Replacement



CAUTION: Ensure that the LN2 supply valve is closed and the plumbing assembly is vented before removing the inline filter.

1. Close the LN2 supply valve and disconnect the LN2 transfer hose from the plumbing assembly fill tee.
47. Loosen and remove the fill tee and inline filter from the plumbing assembly.
48. Replace the inline filter (PN 11648945) and reassemble the fill tee and filter to the plumbing assembly using new Teflon tape if needed. Ensure the filter is oriented correctly so that the affixed arrow indicates the direction of LN2 flow.
49. Reconnect the LN2 transfer hose, open the LN2 supply valve and check fittings for any leaks.

30.2 Solenoid Valve Replacement

All MVE freezers are equipped with electromechanical solenoid valves that have been tested and approved by MVE for cryogenic use. These valves utilize a PTFE seal for optimal sealing in cryogenic environments. Over time, the normal thermal cycling that this seal is subject to will cause it to harden and lose its ability to seal completely. This will result in seepage past the sealing surface which can increase the LN2 consumption of the system, and in extreme cases result in an overflow situation. Thermal cycling through normal operation can also cause moisture ingress into the coil of the solenoid valve. Over time this may cause the connections and wiring in the coil to corrode and may eventually fail. This may result in an inoperative solenoid valve. Always use OE replacement solenoid valves from MVE. Substituting non MVE components may result in inoperable valves and even damage to the CryoVerse™ Connect control system. Damage to the control system due to use of non MVE parts will not be covered by warranty. Replace the valve in its proper flow orientation.



SMC (black) Solenoid Valve Replacement



CAUTION: Ensure that the LN2 supply valve is closed and the plumbing assembly is vented before removing the solenoid valves.

1. Remove the plumbing shroud cover to access the plumbing system.
50. Remove coil retaining clip by inserting a flathead screwdriver between the clip and the edge of the coil body. Twist the screwdriver, and the clip should slide off
51. Remove and discard the coil assembly



52. Using a crescent wrench, loosen hex nut and remove the plunger housing. Remove plunger housing and plunger assembly. Discard these parts
53. Remove any debris that may have collected in brass valve body
54. Inspect the brass valve body of the solenoid valve for nicks or damage. If the sealing surface appears to be in good condition, the valve body may be reused. If the sealing surface is damaged, the plumbing will need to be disassembled and the entire body will need to be replaced (this is not common).
55. Disassemble a new SMC valve using the above procedure
56. Install the new plunger, plunger housing, and coil assembly onto the old valve body. Assembly valve with new components in the reverse order.
57. Verify that no leaks are present using leak detect solution
58. Open the LN2 supply valve and initiate a fill cycle by pressing “Fill Start”. Allow the fill cycle to complete and verify that flow stops at the termination of the fill cycle.

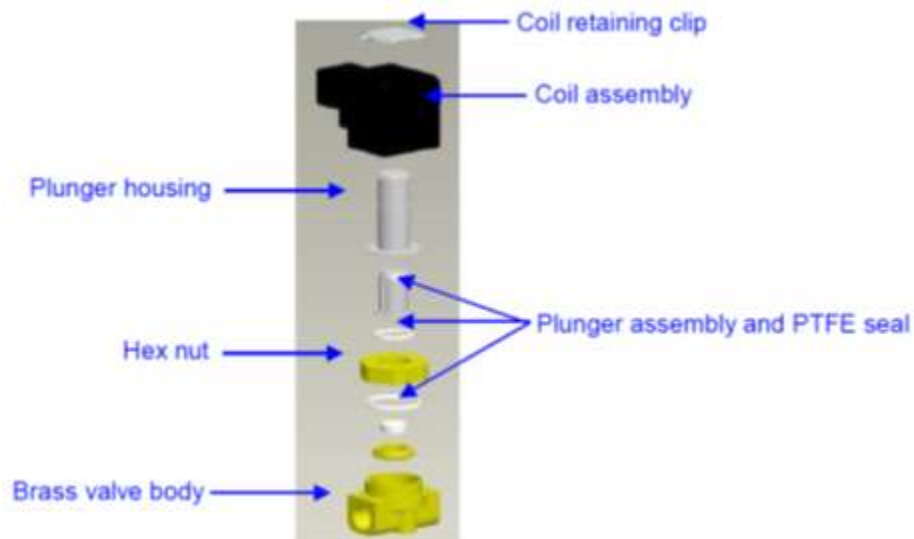

NOTE: If the brass valve body requires replacing, the freezer plumbing will need to be disassembled, and the entire valve replaced. It is typically easier to start disassembling the plumbing assembly beginning at the fill-tee for fill valve replacement or the gas bypass muffler for gas bypass valve replacement.

NOTE: When installing a completely new valve, ensure it is oriented correctly. An “N” is engraved on the side of the SMC brass valve body. The valve should be installed so that this “N” is on the inlet side of the valve.

30.3 Purge Valve Replacement



CAUTION: Ensure that the LN2 supply valve is closed and the plumbing assembly is vented before removing the solenoid valves.

1. Remove the plumbing shroud cover to access the plumbing system.
59. Disconnect the Purge Valve wires from the CryoVerse™ Connect Controller wire harness.
60. Using an adjustable wrench, disconnect the copper tubing from the 2 fittings on the Purge Valve assembly.
61. Disconnect the clear vinyl tubing from the barbed fitting.



62. Remove the two bolts that mount the Purge Valve to the plumbing platform.
63. Repeat steps 1-5 in reverse order to install a new Purge Valve.

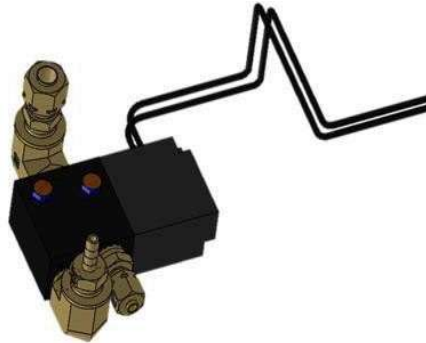

30.4 Relief Valve Replacement



CAUTION: Ensure that the LN2 supply valve is closed and the plumbing assembly is vented before removing the relief valve.

1. Remove plumbing shroud to gain access to plumbing system.
64. If equipped with a relief valve deflector, loosen the deflector clamp and slide off the deflector.
65. Loosen the relief valve and remove it from the plumbing assembly. Be sure to support the attachment tube with wrench to prevent damage from twisting.
66. Install new relief valve (PN 1810032) applying new Teflon tape if needed. Ensure relief valve is rated to 50 PSI (3.4 bar).



CAUTION: Installing a relief valve with a different pressure rating could prevent proper operation and lead to a dangerous over pressurized condition.

Additionally, this will void any warranty.

30.5 Lid Gasket Service & Replacement

Lid Gasket Inspection & Replacement

The lid gasket configuration and material will vary depending on the freezer model and vintage. For the correct part numbers, contact Customer/Technical Service with the freezer serial number. There are three main types of lid gaskets and the replacement instructions for each are given below.

MVE HE Series (Neoprene Tape)

1. Depending on the condition of the current gasket, the gasket material can be removed and replaced or more material can simply be added to the existing gasket.
67. The replacement gasket material will be a neoprene tape.
68. Simply clean the surfaces, remove the tape back to expose the adhesive and install gasket material.
69. Trim to size as needed.
70. Cut a 4-inch gap in the gasket material on either side of the lid as shown below to allow sufficient venting of the freezer space



30.6 Battery Backup Replacement

Battery Backup Replacement and Installation

General

The freezer backup batteries (BB) can be replaced every five years or if the BB voltage has dropped below 21 VDC. To test any suspect BB, disconnect the AC power and allow freezer to run for 30 minutes; the power failure (PF) alarm should trigger. While it is still in PF alarm allows the freezer to perform a fill still using the BB, and once it has reached its high-level set point measure the BB voltage. If the voltage measures 24 to 27 VDC the batteries are good. In any case, the best approach is to always replace a suspect battery or if the battery age is more than five years old.

Note: New batteries may need to be charged for several hours before they are able to power the CryoVerse™ Connect Controller. The Controller constantly monitors, charges, and senses the current in its battery circuit. With its main power connected, the Controller produces a 27 VDC trickle charge to keep the batteries fully charged.

Backup battery replacement installation procedure is as follows:

Each BB utilizes two internal batteries. If performing preventive maintenance, then it is recommended to purchase two cells and replace the internal batteries. See the Battery Replacement section below for replacement instructions.



TOOLS REQUIRED:

1. Phillips Screwdriver
2. Small Flat Head and Phillips Screwdriver
3. Volt/Ohm Meter
4. Wire Ties

UNPACKING

Unpack the assembly and inspect for damage. If any damage is found, a freight claim should be filed with the carrier as soon as possible. Inspect to ensure that all parts of the assembly are included.

BATTERY BACKUP PREVENTATIVE MAINTENANCE AND NEW INSTALLATION

Reference the Battery Replacement section below if just replacing the internal batteries on the BB. This is the recommended preventive maintenance procedure.

Battery Replacement

Make sure the power supply and the battery backup are disconnected.

1. Remove the battery backup assembly from the plumbing stack assembly by removing the four Phillips head screws.

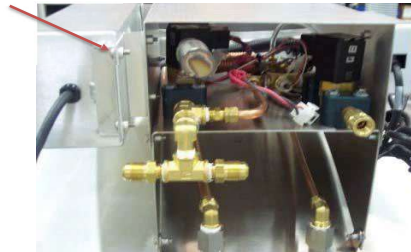

71. Remove the four Phillips screws holding the backing plate.

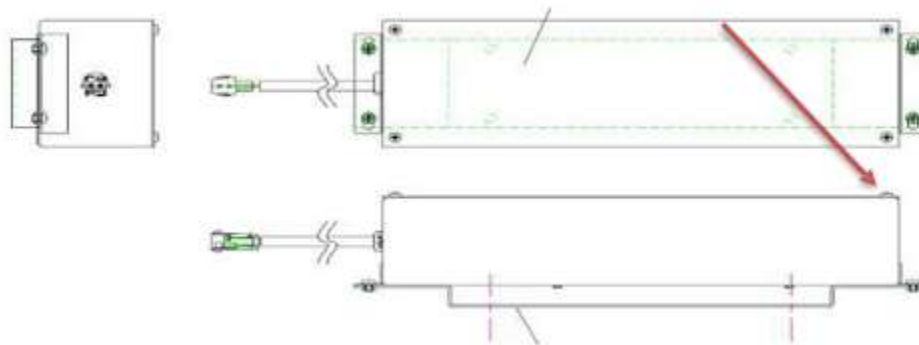

72. Cut the plastic zip ties and remove the batteries by noting the wire connection. Batteries are connected in series - to + as shown in the diagram below.

73. Ensure the cables are routed as shown:

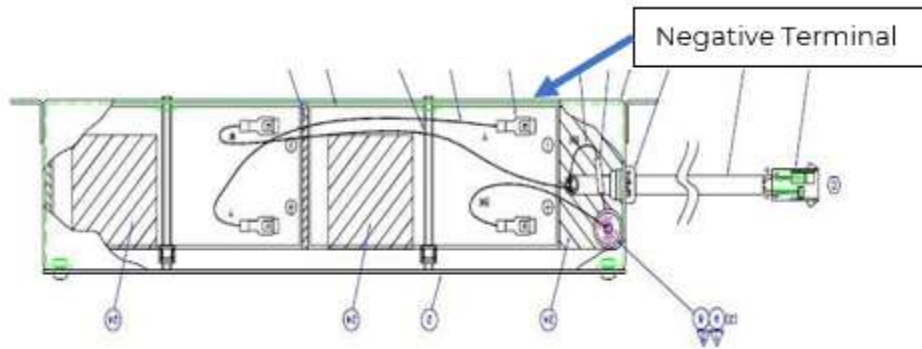

74. Reverse the removal procedure



31 Replacement Parts and Accessories

Replacement Parts	
Part Number	Description
11648945	Inline Filter – 40-micron mesh
20669243	WYE Filter BRZ 1/4FPT 80 Mesh
1810032	Relief Valve – 50 PSI (3.4 bar)
21040465	SMC Solenoid Valve – Fill and Gas Bypass
13284954S	Purge/3-way Solenoid Valve
10713400	Gas Bypass Temperature Sensor – Pt-1000 RTD
11499812	Gas Bypass Muffler
11885449	Gas Bypass Muffler Deflector
21836655	M12-A RTD TEMP PROBE 1000 OHM CryoVerse™ Connect Controller
14248744	HE Series 3-Tube Temperature Sensor Assembly – 26 inch (660 mm)
14248816	HE Series 3-Tube Temperature Sensor Assembly – 39 inch (990 mm)
14248752	HE Series 3-Tube Temperature Sensor Assembly – 44 inch (1118 mm)
21837966	Power supply Input: 100-240 VAC,50/60Hz, 140VA . Output: 36VDC. 1.8A, CryoVerse™ Connect Controller
21838205	POWER CORD 18AWG NEMA 1-15P
21838206	POWER CORD IEC 884/EN50 075
21081273S	Battery Backup Replacement Battery – 12 VDC
11858467	Battery Backup Fuse – 5 x 20 mm, 4A 250VAC
11858467	Power Entry Module Fuse – 5 x 20 mm, 4A 250VAC
21841111	CryoVerse™ Connect Controller

Accessories	
Part Number	Description
20561020	MVE LN2 Level Dip Stick, 47"
13376947	TEC COM USB Kit – TEC 3000 – PC interface kit
10856321	Daisy Chain Kit – Network TEC 3000s – One network cable and splitter
10740053	RJ-45 Network Cable
10856312	RJ-45 Jack Splitter
11358251	OFAF Master Cable
10784443*	Fill Valve Tee Assembly – Tee two freezer to one LN2 supply connection
1611592	Relief Valve Pipe Away Adapter – 3/8 inch NPT Outlet
1810092	Relief Valve Pipe Away Adapter – ½ inch NPT Outlet
13051579	Cool Reach Cryogenic Claw
9713159	LN2 Transfer Hose – 4 ft (1220 mm), ½ inch (12.7 mm) ODT
9713109	LN2 Transfer Hose – 6 ft (1829 mm), ½ inch (12.7 mm) ODT
21837350	LN2 6ft Vacuum Jacketed Transfer Hose
1110862	LN2 Transfer Hose Coupler – Daisy chain two transfer hoses
9717119	Cryo Gloves – Size: Medium; Length: Mid-arm
9717129	Cryo Gloves – Size: Large; Length: Mid-arm
9717139	Cryo Gloves – Size: X-Large; Length: Mid-arm
9717149	Cryo Gloves – Size: Medium; Length: Elbow
9717159	Cryo Gloves – Size: Large; Length: Elbow
9717169	Cryo Gloves – Size: X-Large; Length: Elbow
10464394	Cryo Apron
13934911	Automatic LN2 Supply Switch



32 Troubleshooting Quick Reference

Symptom	Possible Causes	Fixes	Instructions
Freezer not filling	Improperly connected LN2 supply	Verify LN2 connections	Equipment Usage
	Inadequate LN2 supply volume or pressure	Verify adequate supply	Verify Adequate LN2 Supply
	Fill solenoid valves not opening	Verify fill solenoid resistance	Solenoid Valve Replacement
		Check fill solenoid valves for debris	
	Lid switch not engaged	Verify lid switch settings and functionality	Lid Switch Settings
	Current LN2 level at or above the high level setpoint	Verify current LN2 level and level control settings	Liquid Level Settings
Auto Fill disabled	Press Start Fill to verify manual operation. Confirm auto fill settings	Auto Fill Control	
Slow fills or Long fill times	Inadequate LN2 supply	Verify adequate supply	Verify Adequate LN2 Supply
	Clogged inline filter	Clean/replace inline filter	Inline Filter Replacement
	Fill solenoid valves not opening all the way	Verify fill solenoid resistance	Solenoid Valve Replacement
		Check fill solenoid valves for debris	
Leak in plumbing or LN2 supply connection	Check for leaks	Plumbing Leak Check	
Incorrect temperature readings	Verify temp sensor connection	Check temp sensor connector and controller connections	Connect Temp A to Temp B and verify if condition follows the sensor
	Restore to defaults, improperly calibrated or requires recalibration	Recalibrate temperature sensor	Temperature Sensor Calibration
	Faulty temperature probe	Confirm resistance values and replace if necessary	Resistance Table
Incorrect LN2 level readings	Requires OFFSET adjustment	Perform LN2 level check	LN2 Level OFFSET adjustment
	Disconnected clear vinyl tube	Check clear vinyl tube connections and integrity	Plumbing Leak
	Leak in level sensing line	Perform leak test on purge valve, vinyl tube, and fittings	



Symptom	Possible Causes	Fixes	Instructions
	Purge valve defective	Check resistance of purge valve	Purge valve replacement
	Insufficient freezer venting	Increase lid gasket vent. Replace gasket/lid if necessary	Lid Gasket Replacement
	Obstruction in level sensing line	Purge level sensing annular line and clear any debris in the bottom of freezer. Complete freezer thaw and moisture removal may be necessary	Complete Freezer Thaw and Moisture Removal
Consistent power failure alarms	Non-uniform AC voltage (dirty power)	Install uninterruptable power supply (UPS), Battery Backup, or quality surge protector	
	Transition to generator power		
Short cycle fills	Inaccurate level readings	See "Incorrect LN2 level readings" above.	
	Insufficient freezer venting	Increase lid gasket vent. Replace gasket/lid if necessary	Lid Gasket Replacement
	Obstruction in level sensing line	Purge level sensing annular line and clear any debris in the bottom of freezer. Complete freezer thaw and moisture removal may be necessary	Complete Freezer Thaw and Moisture Removal



33 EN Compliance Table

This equipment has been tested and found to comply with the electromagnetic compatibility requirements of IEC 60601-1-2 Edition 4.1 (2020). It is intended for use in the professional healthcare environment as defined by the standard. The device maintains basic safety and essential performance when exposed to the electromagnetic disturbances specified for this environment. No special electromagnetic precautions are required beyond those described in this manual.

Table 17. Guidance and manufacturer's declaration – electromagnetic emissions for all CryoVerse Controller (See 5.2.2.1 C).

Guidance and Manufacturer's Declaration - Electromagnetic Emissions		
The CryoVerse™ Connect Controller is intended for use in the electromagnetic environment specified below. The customer or the user of the CryoVerse™ Connect Controller should assure that it is used in such an environment.		
Emissions Test	Compliance	Electromagnetic Environment – Guidance
RF emissions CISPR 11	Group 1	The CryoVerse™ Connect Controller uses RF energy for its internal functions and 2.4/5.0 GHz WIFI. Therefore, its RF emissions are very low and are not likely to cause any interference in nearby electronic equipment.
RF emissions CISPR 11	Class A	The CryoVerse™ Connect Controller is suitable for use in laboratory and professional settings.
Harmonic emissions IEC 61000-3-2	Class A	
Voltage fluctuations / Flicker emissions IEC 61000-3-3	Complies	

Table 18. Guidance and manufacturer's declaration – electromagnetic immunity – for all CryoVerse™ Connect Controller (See 5.2.2.1 F)

Guidance and Manufacturer's Declaration – Immunity			
The EUT is intended for use in the electromagnetic environment specified below. The customer or user of the EUT should ensure that it is used in such an environment.			
Immunity Test	IEC 60601 Test Level	Compliance Level	Electromagnetic Environment – Guidance
ESD IEC 61000-4-2	±8kV Contact ± 2 kV, ± 4 kV, ± 8 kV, ± 15 kV air	±8kV Contact ± 2 kV, ± 4 kV, ± 8 kV, ± 15 kV air	Floors should be wood, concrete or ceramic tile. If floors are synthetic, the r/h should be at least 30%
Electrical Fast Transient/Burst IEC 61000-4-	±2 kV 100 kHz repetition frequency	±2 kV 100 kHz repetition frequency	Mains quality of power should be that of a typical commercial or hospital environment.
	±0.5 kV, ±1 kV	±0.5 kV, ±1 kV	Mains power quality should be that of a
Surge	Line-to-line	Line-to-line	typical commercial or hospital



Guidance and Manufacturer's Declaration – Immunity			
The EUT is intended for use in the electromagnetic environment specified below. The customer or user of the EUT should ensure that it is used in such an environment.			
Immunity Test	IEC 60601 Test Level	Compliance Level	Electromagnetic Environment – Guidance
IEC 61000-4-5	±0.5 kV, ±1 kV, ± 2 kV	±0.5 kV, ±1 kV, ± 2 kV	environment.
	Line-to-ground	Line-to-ground	
Voltage dips, short interruptions and voltage variations on power supply input lines IEC 61000-4-11	0 % UT; 0,5 cycle At 0°, 45°, 90°, 135°, 180°, 225°, 270° and 315° 0 % UT; 1 cycle 70 % UT; 25/30 cycles Single phase: at 0°	0 % UT; 0,5 cycle At 0°, 45°, 90°, 135°, 180°, 225°, 270° and 315° 0 % UT; 1 cycle 70 % UT; 25/30 cycles Single phase: at 0°	Mains quality of power should be that of a typical commercial or hospital environment. If the Use of the CryoVerse™ Connect Controller requires continued operation during power mains interruptions, it is recommended that the CryoVerse™ Connect Controller be powered by an uninterruptible power supply or battery.
	0 % UT; 250/300 cycle	0 % UT; 250/300 cycle	
Power frequency (50/60 Hz) Magnetic field IEC 61000-4-8	30A/M 50/60 Hz	30A/M 50/60 Hz	Power frequency magnetic fields should be those of a typical commercial or hospital environment.

Table 19. Guidance and manufacturer's declaration – electromagnetic immunity – for all CryoVerse Controller (See 5.2.2.2)

Guidance and Manufacturer's Declaration – Immunity			
The EUT is intended for use in the electromagnetic environment specified below. The customer or user of the EUT should ensure that it is used in such an environment.			
Immunity Test	IEC 60601 Test Level	Compliance Level	Electromagnetic Environment – Guidance
			Portable and mobile RF communications equipment should be used no closer to any part of the CryoVerse™ Connect Controller including cables, than the recommended separation distance calculated from the equation applicable to the frequency of the transmitter. Recommended distance separation $d = 1,2\sqrt{P}$
Conducted RF IEC	3 Vrms	3Vrms	$d = 1,2\sqrt{P}$ $d = 2,3\sqrt{P}$



Guidance and Manufacturer's Declaration – Immunity			
The EUT is intended for use in the electromagnetic environment specified below. The customer or user of the EUT should ensure that it is used in such an environment.			
Immunity Test	IEC 60601 Test Level	Compliance Level	Electromagnetic Environment – Guidance
61000-4-6			
	6Vrms (In ISM Bands) 150 kHz to 80 MHz	6Vrms (In ISM Bands) 150 kHz to 80 MHz	where P is the maximum output power rating of the transmitter in watts (W) according to the transmitter manufacturer and d is the recommended separation distance in meters (m).
			Field strengths from fixed RF transmitters, as determined by an electromagnetic site survey a, should be less than the compliance level in each frequency range b.
Radiated RF IEC 61000-4-3	80MHz to 2.7GHz	3 V/m 80 MHz – 2,7 GHz 80 % AM at 1 kHz	Interference may occur in the vicinity of equipment marked  with the following symbol:
NOTE 1: At 80 MHz and 800 MHz the higher frequency range applies			
NOTE 2: These guidelines may not apply in all situations. Electromagnetic propagation is affected by absorption and reflection from structures, objects, and people. a Field strength from fixed transmitters such as base stations for radio (cellular/cordless) telephones and land mobile radios, amateur radio, AM, and FM radio broadcast and TV broadcast cannot be predicted theoretically with accuracy. To assess the electromagnetic environment due to fixed RF transmitters, an electromagnetic site survey should be considered. If the measured field strength in the location in which the CryoVerse™ Connect Controller is used exceeds the applicable RF compliance level above, the CryoVerse™ Connect Controller should be observed to verify normal operation. If abnormal performance is observed, additional measures may be necessary, such as reorienting or relocating the CryoVerse™ Connect Controller.			
b Over the frequency range 150 kHz to 80 MHz, field strengths should be less than 3 V/m.			



Test frequency (MHz)	Band ^{a)} (MHz)	Service ^{a)}	Modulation ^{b)}	Maximum power (W)	Distance (m)	IMMUNITY TEST LEVEL (V/m)
385	380 – 390	TETRA 400	Pulse modulation ^{b)} 18 Hz	1,8	0,3	27
450	430 – 470	GMRS 460, FRS 460	FM ^{c)} ± 5 kHz deviation 1 kHz sine	2	0,3	28
710	704 – 787	LTE Band 13, 17	Pulse modulation ^{b)} 217 Hz	0,2	0,3	9
745						
780						
810	800 – 960	GSM 800/900, TETRA 800, iDEN 820, CDMA 850, LTE Band 5	Pulse modulation ^{b)} 18 Hz	2	0,3	28
870						
930						
1 720	1 700 – 1 990	GSM 1800; CDMA 1900; GSM 1900; DECT; LTE Band 1, 3, 4, 25; UMTS	Pulse modulation ^{b)} 217 Hz	2	0,3	28
1 845						
1 970						
2 450	2 400 – 2 570	Bluetooth, WLAN, 802.11 b/g/n, RFID 2450, LTE Band 7	Pulse modulation ^{b)} 217 Hz	2	0,3	28
5 240	5 100 – 5 800	WLAN 802.11 a/n	Pulse modulation ^{b)} 217 Hz	0,2	0,3	9
5 500						
5 785						

Table 20. Recommended separation distances between portable and mobile RF communications equipment and the CryoVerse™ Connect Controller systems that are not life supporting (See 5.2.2.2)

Recommended separation distances between portable and mobile RF communications equipment and the CryoVerse Controller			
The CryoVerse™ Connect Controller is intended for use in the electromagnetic environment in which radiated RF disturbances are controlled. The customer or the user of the CryoVerse™ Connect Controller can help prevent electromagnetic interference by maintaining a minimum distance between portable and mobile RF communications equipment (transmitters) and the CryoVerse™ Connect Controller as recommended below, according to the maximum output power of the communications equipment.			
Rated maximum output power of transmitter (W)	Separation distance according to frequency of transmitter (m)		
	150 kHz to 80 MHz $d = 1,2\sqrt{P}$	80 MHz to 800 MHz $d = 1,2\sqrt{P}$	800 MHz to 2,5 GHz $d = 2,3\sqrt{P}$
0,01	0,12	0,12	0,23
0,1	0,38	0,38	0,73
1	1,2	1,2	2,3
10	3,8	3,8	7,3
100	12	12	23



For transmitters rated at a maximum output power not listed above, the recommended separation distance d in meters (m) can be estimated using the equation applicable to the frequency of the transmitter where P is the maximum output power rating of the transmitter in watts (W) according to the transmitter manufacturer.

NOTE 1: At 80 MHz and 800 MHz, the separation distance for the higher frequency range applies

NOTE 2: These guidelines may not apply in all situations. Electromagnetic propagation is affected by absorption and reflection from structures, objects, and people.

NOTE: Medical Electrical Equipment needs special precautions regarding EMC and needs to be installed and put into service according to the EMC information provided in this manual.

NOTE: Portable and mobile RF communications equipment can affect Medical Electrical Equipment.

NOTE: The use of accessories, transducers and cables other than those specified, except for the transducer and cables sold by the manufacturer of this device as replacement parts for internal components, may result in increased emissions or decreased immunity of the CryoVerse™ Connect Controller 

NOTE: The CryoVerse™ Connect Controller should not be used adjacent or stacked with other equipment and that if adjacent or stacked use is necessary, the CryoVerse™ Connect Controller should be observed to verify normal operation in the configuration in which it will be used.

DISPOSAL OF PRODUCT:

Stainless Steel Freezer:

Freezers used to store biological materials require decontamination prior to disposal. Contact MVE for decontamination information.

CryoVerse™ Connect Controller:

Local or national environmental laws and regulations may prohibit the disposal of electrical and/or electronic equipment such as the CryoVerse™ Connect Controller. Contact the local city or town offices for instructions on proper disposal of electrical or electronic equipment. Alternatively, MVE may be contacted for disposal information.



34 Appendix (Reference Tables)

Table 21. Temperature vs. Resistance Output (ohms) for Pt-1000 Temperature Sensors

Temp°C	-0	-1	-2	-3	-4	-5	-6	-7	-8	-9
-200	185.201									
-190	228.255	223.965	219.672	215.376	211.076	206.772	202.465	198.154	193.840	189.522
-180	270.964	266.708	262.449	258.186	253.920	249.651	245.379	241.103	236.824	232.541
-170	313.350	309.126	304.898	300.667	296.434	292.197	287.956	283.713	279.467	275.217
-160	355.433	351.238	347.040	342.839	338.635	334.429	330.219	326.006	321.791	317.572
-150	397.232	393.064	388.894	384.721	380.545	376.367	372.186	368.002	363.815	359.626
-140	438.764	434.622	430.478	426.331	422.182	418.030	413.876	409.719	405.559	401.397
-130	480.048	475.930	471.810	467.688	463.563	459.436	455.307	451.175	447.040	442.904
-120	521.098	517.003	512.906	508.806	504.705	500.601	496.495	492.386	488.276	484.163
-110	561.930	557.856	553.780	549.702	545.622	541.540	537.456	533.370	529.281	525.191
-100	602.558	598.504	594.448	590.391	586.331	582.269	578.205	574.139	570.072	566.002
-90	642.996	638.960	634.923	630.884	626.843	622.800	618.756	614.709	610.661	606.611
-80	683.254	679.236	675.217	671.195	667.172	663.147	659.120	655.092	651.062	647.030
-70	723.345	719.344	715.340	711.335	707.328	703.320	699.310	695.299	691.286	687.271
-60	763.278	759.292	755.304	751.315	747.324	743.331	739.337	735.341	731.344	727.346
-50	803.063	799.091	795.117	791.143	787.166	783.189	779.210	775.229	771.247	767.263
-40	842.707	838.748	834.789	830.828	826.865	822.902	818.937	814.970	811.003	807.033
-30	882.217	878.271	874.325	870.377	866.428	862.478	858.526	854.573	850.619	846.663
-20	921.599	917.666	913.732	909.797	905.861	901.923	897.985	894.044	890.103	886.160
-10	960.859	956.938	953.016	949.093	945.169	941.244	937.317	933.390	929.461	925.530
0	1000.00	996.091	992.181	988.270	984.358	980.444	976.529	972.613	968.696	964.778
	+0	+1	+2	+3	+4	+5	+6	+7	+8	+9
0	1000.00	1003.91	1007.81	1011.72	1015.62	1019.53	1023.43	1027.33	1031.23	1035.13
10	1039.03	1042.92	1046.82	1050.71	1054.60	1058.49	1062.38	1066.27	1070.16	1074.05
20	1077.94	1081.82	1085.70	1089.59	1093.47	1097.35	1101.23	1105.10	1108.98	1112.86
30	1116.73	1120.60	1124.47	1128.35	1132.21	1136.08	1139.95	1143.82	1147.68	1151.55
40	1155.41	1159.27	1163.13	1166.99	1170.85	1174.70	1178.56	1182.41	1186.27	1190.12
50	1193.97	1197.82	1201.67	1205.52	1209.36	1213.21	1217.05	1220.90	1224.74	1228.58
60	1232.42	1236.26	1240.09	1243.93	1247.77	1251.60	1255.43	1259.26	1263.09	1266.92
70	1270.75	1274.58	1278.40	1282.23	1286.05	1289.87	1293.70	1297.52	1301.33	1305.15
80	1308.97	1312.78	1316.60	1320.41	1324.22	1328.03	1331.84	1335.65	1339.46	1343.26
90	1347.07	1350.87	1354.68	1358.48	1362.28	1366.08	1369.87	1373.67	1377.47	1381.26



35 Decontamination and Sanitizing

The stainless units are constructed with an inner entirely fabricated from stainless steel and aluminum sheets. Any cleaning solution that does not react with aluminum or stainless can be used in the sanitation process of these dewars. In most cases, any household detergent or mild soap solution is suitable. The U.S. Custom Service uses a solution called EXSPOR for incoming shipments from abroad. This is mixed 9 parts water mixed with sodium chloride & lactic acid. As mentioned above, however, any household cleaning solution can be used. These include bleach, detergents, and mild soaps. Other cleaners and disinfectants that can be safely used include hydrogen peroxide, chlorine/water and denatured alcohol. NOTE: DO NOT USE ANY PETROLEUM BASED CLEANING SOLUTION. It is important that the inner vessel is thoroughly rinsed with water and all cleaner residues have been removed. Spraying the solution into the inner vessel is preferred, although agitation of the solution inside the inner will suffice. Vapor shippers and Doble units will require filling the inner to its full capacity with cleaning mixture and then rinsing. Allow the unit to dry thoroughly before putting it into service. With vapor shippers, we suggest setting dewar inverted to drain and dry. The process is not intended for use in older vapor shipper models manufactured prior to 1994.

The generally accepted practice of using 10% chlorine bleach with 90% water solution still holds as the best method for decontamination. However, with some of the bovine and swine virus strains showing up today, it is the conclusion of the agricultural professors at the University of Minnesota and Texas A & M that an increased mixture of chlorine bleach to 30% and 70% water will kill most known viruses except BSE.

To perform this sanitizing procedure, cover all inner surfaces with the solution, let stand for 30 minutes and remove. Rinse the decontaminated surfaces with clean water and remove rinse water. Allow dewar to dry before putting into service. For vapor shippers and Doble units, this means to place dewar on end (inverted) and allow drying. Note: Vapor dewars can be used immediately after rinsing but may take longer to recharge to 100% capacity.